

دوره آموزشی PFD-P&ID

PFD-P&ID training course

تهیه کننده : محمد بهزادی Mohammad Behzadi

وبلاگ آموزشی: www.mblastsavior.mihanblog.com
پست الکترونیکی: Lastsavior_b@yahoo.com

تقدیم به برادرم سعید رادپور که با بخشش علمی بیدریغ خود استاد و قطب نمای علمی در مسیر زندگیم بود

تذکر: برای دیدن راهنمای مطالب لازم است تا از آکروبات 7 یا بالاتر استفاده شود

Acrobat 7.0 or higher is needed for view commenting!

PFD-P&ID course

Produced by: Mohammad Behzadi

تهیه کننده : محمد بهزادی

APPLIED PROCESS DESIGN

FOR CHEMICAL AND PETROCHEMICAL PLANTS

Volume 1, Third Edition

Emphasizes how to apply techniques of process design and interpret results into mechanical equipment details



Ernest E. Ludwig

منابع مطالعاتي

- Volume 1:**
1. Process Planning, Scheduling, Flowsheet Design
 2. Fluid Flow
 3. Pumping of Liquids
 4. Mechanical Separations
 5. Mixing of Liquids
 6. Ejectors
 7. Process Safety and Pressure-Relieving Devices
Appendix of Conversion Factors
- Volume 2:**
8. Distillation
 9. Packed Towers
- Volume 3:**
10. Heat Transfer
 11. Refrigeration Systems
 12. Compression Equipment (Including Fans)
 13. Reciprocating Compression Surge Drums
 14. Mechanical Drivers

Chemical Process Equipment

Selection and Design

Stanley M. Walas

Butterworth-Heinemann Series in Chemical Engineering

THIRD EDITION

RULES OF THUMB FOR CHEMICAL ENGINEERS

A manual of quick, accurate solutions to
everyday process engineering problems

CARL BRANAN



Standards

IRANIAN

IPS (IRANIAN PETROLEUM STANDARDS)
IGS (IRANIAN GAS STANDARDS)

ASME (AMERICAN SOCIETY OF MECHANICAL ENGINEERS)

ANSI (AMERICAN NATIONAL STANDARD INSTITUTE)

API (AMERICAN PETROLEUM INSTITUTE)

ISO (INTERNATIONAL ORGANIZATION FOR STANDARDIZATION)

GPSA (Gas Process System Association)

ISA (INSTRUMENT SOCIETY OF AMERICA)

BSI (BRITISH STANDARD INSTITUTE)

✦ کد توصیه هایی برای طراحی و عملیات

✦ استاندارد شامل اندازه ها و اجزا

✦ Design factor

✦ ایمنی (مثلا برای دبی 10 درصد)



استانداردهای معروف برای دیسیپلین های مختلف

3. APPLICABLE CODES & STANDARDS

3.1. Process

API 2000	Venting of Atmospheric or Low pressure Storage Tanks
API RP 521	Guide for Pressure-Relieving and Depressuring Systems
API RP 520	Sizing and Selection and Installation of Pressure Relief Devices
API publ. 2210	Flame Arresters for Vents of Tanks Storing Petroleum Product
IEC 79-10	Classification of Hazardous Areas
ISGOTT	International Safety Guide for Oil Tankers and Terminals (International Chamber of Shipping - Oil Companies International Forum - International Association of Ports and Harbours, ISBN 185609 081 7)
IMO	Crude Oil Washing (IMO publication, ISBN 92 801 50944)
IMO	Inert Gas Systems (IMO publication ISBN 92 801 1262 7)

استانداردهای معروف برای دیسیپلین های مختلف

Fire Fighting

Iranian Petroleum Standard

IPS-C-SF-242	Standard for Delivery, Inspection, and Quality Control and Commissioning of Firefighting Pumps
IPS-C-SF-505	Standard for Installation, Inspection and Testing of Firefighting Systems
IPS-E-SF-100	Classification of Fire Hazard Properties
IPS-E-SF-140	Foam Generating and Proportioning Systems
IPS-E-SF-200	Fire Fighting Sprinkler Systems
IPS-E-SF-220	Fire Water Distribution and Storage Facilities
IPS-E-SF-260	Automatic Detectors and Fire Alarm Systems)
IPS-E-SF-380	Fire Protection in Buildings
IPS-G-IN-270	General Standard for Fire Fighting & Detection Equipment
IPS-G-SF-202	Mains Water-Sprinkler-Dcp-CO ₂ and Foam Systems
IPS-G-SF-240	Fire fighting Pumps Systems and Trailers
IPS-M-SF-105	Valves, Reels, Hoses, Nozzle and Monitors for Fire Fighting
IPS-M-SF-142	Fle-Foam Proportioners-Generators and Twin Agents
IPS-M-PM-125	Material and Equipment Standard for Fire Water Pumps

استانداردهای معروف برای دیسپلین های مختلف

Safety

Iranian Petroleum Standard

IPS-C-SF-550 Safety Boundary Limit

Swedish Standard – European Standard

SS-EN 1050 Safety of Machinery - Principles for Risk Assessment

SS-EN 1070 Safety of Machinery – Terminology

Occupational Safety And Health Administration

Part 1910

International Organization for Standardization

ISO 10418 Hazop

National Institute Of Occupational Safety And Health.

Occupational Safety and Health Guidelines for Chemical Hazards

Environmental

Iranian Petroleum Standard

IPS-E-SF-860 Air Pollution Control

IPS-G-SF-900 Noise Control

استانداردهای معروف برای دیسپلین های مختلف

Civil

The following codes and standards, which are listed in 5-2-1-2, are to be used for the civil Basic Design:

BS 8110	part 1 & 2	Structural use of concrete
BS 6031		Code of practice for earthworks
BS 8004		Code of practice for foundations
BS 6399 part 1		Loading for buildings

www.mblast Savior.mihanblog.com

Mechanical

API 610,	Centrifugal Pumps for General Refinery Service
API 671	Special Purpose Couplings
EN 292	Safety of Machinery
ASME Section IV	Heating boilers.
API 650	Welded Steel Tanks for Oil Storage
API 661	Air Cooled Heat Exchangers for General refinery service
NORSOK M-CR-501	Surface Protection and Protective Coating
NORSOK R-001	Mechanical Equipment
API Spec 5L:	Specification for Line Pipe, Forty-first Edition, April 1, 1995
IPS	Iranian Petroleum Standards
IPS-M-PI-110	Material and Equipment Standard for Valves
IPS-G-SF-900	General Standard for Noise Control and Vibration

استانداردهای معروف برای دیسپلین های مختلف

Piping

ANSI B31.4	Pipeline Transportation Systems for Liquid Hydrocarbons and other Liquids Pipeline Transportation Systems for Liquid Hydrocarbons and other Liquids
ANSI B31.3	Process Piping
ANSI B16.34	Valves-Flanges, Threaded and Welding End Pipe Flanges and Flanged Fittings
ANSI B16.20	Metallic Gaskets
API 6D	Specification for Pipe Line Valves
ASME Section IX	Welding and Brazing Qualifications
NORSOK L-CR-003	Piping Details (except from chap. 5.5.)
API 5L	Specification of Line Pipe
API 1104	Standard for Field Welding of Pipelines
ANSI B16.5	Standard for Steel Pipe Flanges and Flanged Joints Painting Application Specification

www.mblastsavior.mihanblog.com

استانداردهای معروف برای دیسیپلین های مختلف

IPS-E-PI-240	Engineering Standard for Plant Piping Systems
IPS-E-PI-200	Flexibility Analysis
IPS-G-PI-280	Pipe Supports
IPS-M-PI-110	Material and Equipment Standard for Valves
IPS-M-PI-150	Flanges & Fittings
IPS-E-PR-190	Layout & Spacing
IPS-E-PR-200	Basic Engineering Design Data
IPS-E-PR-230	Piping & Instrument Diagrams
IPS-E-PR-460	Process Design of Flare & Blowdown Systems
IPS-D-PI-102	Typical Unit Arrangement & Piperack Layout
IPS-D-PI-113	Y-Type Suction Strainer
IPS-D-PI-114	T-Type Suction Strainer
IPS-D-PI-122	Control Valve Piping Manifolds
IPS-D-PI-123	Relief Valve Installation and Relief System
IPS-D-PI-128	Utility Station, Hose Rack & Emergency Shower Details
IPS-D-PI-140	Sample Point Assembly for Piping

محدودیت

✦ خارجی:

✦ ویژگی محصول

✦ شرایط ایمنی

✦ ویژگی فاضلاب

✦ داخلی:

✦ استوکیومتری

✦ معادلات شیمیایی

✦ معادلات فیزیکی جداسازی

✦ آزنوتروپ

✦ قیدهای عمومی موازنه انرژی



EPC

- Engineering
- Procurement
- Construction



Flowsheets

+ Basic Design

- BFD (BLOCK FLOW DIAGRAM)
- PFD (PROCESS FLOW DIAGRAM)

+ Detailed Design

- P&ID (PROCESS & INSTRUMENTATION DIAGRAM)
- UFD (UTILITY FLOW DIAGRAM)
- UHD (UTILITY HEADER DIAGRAM)

PFD (process flow diagram)

نقشه شماتیکی است که تعریف کلی از فرایند سیستم را توسط نمایش تجهیزات و خطوط اصلی فرایند همراه با مشخصات پروسسی این خطوط ارائه میدهد. این مشخصات عموماً شامل درجه حرارت و فشار کاری (عملیاتی)، دبی جریان، دانسیته و ویسکوزیته، میزان و یا درصد عناصر مهم در خطوط مختلف میباشد.

P&ID (piping and instrumentation diagram)

نقشه شماتیکی است که شامل کلیه تجهیزات مکانیکی، خطوط ارتباطی، تجهیزات ابزار دقیق، سیستمهای کنترلی و اینترلاکها است. به عبارت دیگر کلیه اقلام و تجهیزات مکانیکی، لوله کشی و ابزار دقیق در این نقشه به طور شماتیک نشان داده میشوند ولی اندسته از اقلام لوله کشی که در طراحی piping layout (چیدمان لوله کشی) مورد نیاز واقع میشوند در نقشه P&ID دیده نمیشوند از جمله زانویی ها که دقیقاً بستگی به طریقه چیدمان لوله کشی دارند.

UHD (utility header diagram)

نقشه های شماتیکی هستند که توزیع سیالات غیر پرورسی (جانبی) را از خروجی واحد تولید کننده این سیالات، تا مرز ورودی واحدهای مصرف کننده (پروسسی) نشان میدهد. همچنین در داخل واحدهای پروسسی نیز این دیاگرامها توزیع سیالات غیر پرورسی (utility) در واحد را نمایش میدهند.

"P&ID" INPUT DATA

www.mblastsavior.mihanblog.com

اطلاعات مورد نیاز جهت طراحی P&ID

ITEM	DESCRIPTION
01	PROJECT DESIGN CRITERIA ظوابط طراحی پروژه
02	PROCESS FLOW DIAGRAM (PFD) فلو شیت پروسسی
03	PIPING MATERIAL SPEC. مشخصات فنی لوله کشی
04	PROCESS DATA SHEET
05	EQUIPMENT PROCESS DATA
06	INSTRUMENT DATA
07	ENG. PRACTICE CODE AND STANDARD استانداردهای مورد نیاز همراه با تجربیات و دستورالعملها
08	LEGEND AND SYMBOLS

نکات مهم در کنترل نحوه نقشه‌کشی نقشه PFD

ITEM	DESCRIPTION	www.mblastsavior.mihanblog.com
01	IS LAY OUT ACCEPTABLE?	آیا شکل نقشه از نظر میزان پراکندگی تجهیزات و لوله‌کشی یکنواخت است
02	DIRECTION OF FLOWS?	جهت جریان‌ات زده شده باشد
03	THICKNESS AND TYPE OF LINES FOR INDICATION OF MAIN PROCESS, SECONDARY PROCESS, UTILITIES, SIGNALS, ETC. ARE CORRECT?	ضخامت خطوط متناسب با نوع جریان انتخاب شده باشد (خطوط اصلی پررنگتر از خطوط فرعی بوده و جهت نشان دادن سیگنال‌های ابزار دقیق از خط متفاوتی استفاده شود)
04	CROSSING ARE CORRECT?	خطوطی که هاز روی هم رد میشوند با یکدیگر برخورد نداشته باشند
05	BATTERY LIMITS, AND ADDRESSES ARE SHOWN CORRECTLY?	مرز نقشه مشخص شده باشد و آدرس خطوط در ورود و خروج به واحد داده شده باشد.
06	LEGEND OF EQ. ARE CORRECT?	شکل شماتیکی تجهیزات مطابق با LEGEND قراردادی انتخاب شده باشد
07	STRAM NOS ARE AS REQUIRED FOR MAKING BALANCE AROUND ALL EQ.?	شماره جریان‌ات که با استفاده از آن در جدول MATERIAL BALANCE مشخصات پروسسی داده میشود به تعداد کافی نشان داده شده باشد
08	TITLE BLOCK IS CORRECTLY COMPLETED?	جدول عنوان نقشه به درستی تکمیل شده باشد

هدر (header , manifold) لوله‌هایی که جهت جمع‌آوری سیال از چند خط، چند پمپ، و یا چند شیر اطمینان (safety valve) و، و ارسال این سیال به یک یا چند خط بکار میروند.

شیر اطمینان (safety valve) شیرهایی که روی خطوط لوله و یا مخازن تحت فشار نصب میشوند و در صورت بروز پدیده افزایش فشار بیش از میزان تعیین شده (set point) باز شده و بخشی از سیال را از خط و یا مخزن تحت فشار تخلیه کرده و فشار آن را به زیر میزان تعیین شده کاهش میدهد.

شیر کنترل (control valve) شیرهای اتوماتی هستند که به منظور کنترل پارامترهایی مانند فشار، دبی، درجه حرارت و ... در خط تعبیه شده و بنا به نوع کنترلی که دارند از pressure transmitter، temperature transmitter و یا سایر تجهیزات اندازه‌گیری با برنامه‌ای که در DCS با عنوان logic diagram برای آنها تعریف میشود پارامتر مورد نظر را کنترل مینمایند. عملگر این شیرها عموماً هوای ابزار دقیق میباشد (pneumatic actuator)

drain و Vent به ترتیب شیر تخلیه هوا که در بالاترین نقطه خط نصب میشود و جهت تخلیه هوا از خط مورد استفاده قرار میگیرد و شیر تخلیه مایع که در پایین‌ترین نقطه خط نصب شده و جهت تخلیه مایع استفاده میشود.

UTILITY HEADER DIAGRAM

"UHD" INPUT DATA

ITEM	DESCRIPTION
01	PROJECT DESIGN CRITERIA
02	P&ID
03	PIPING LAYOUT DRAWIND
04	PROCESS DATA
05	ENG. PRACTICE
06	LEGEND AND SYMBOLS

www.mblastsavior.blogfa.com

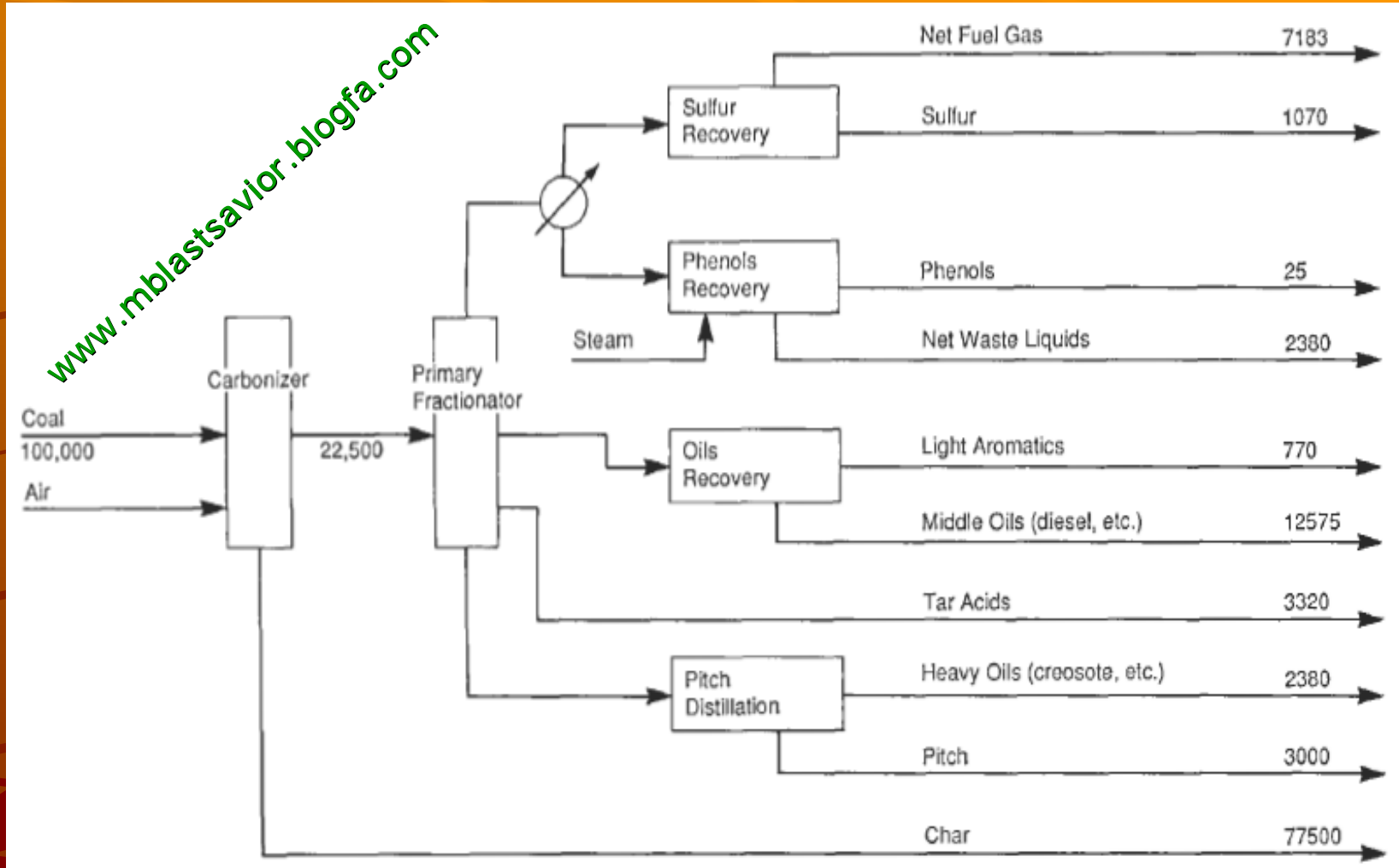

Coal carbonization block flowsheet. Quantities are in lb/hr

BFD (BLOCK FLOW DIAGRAM)

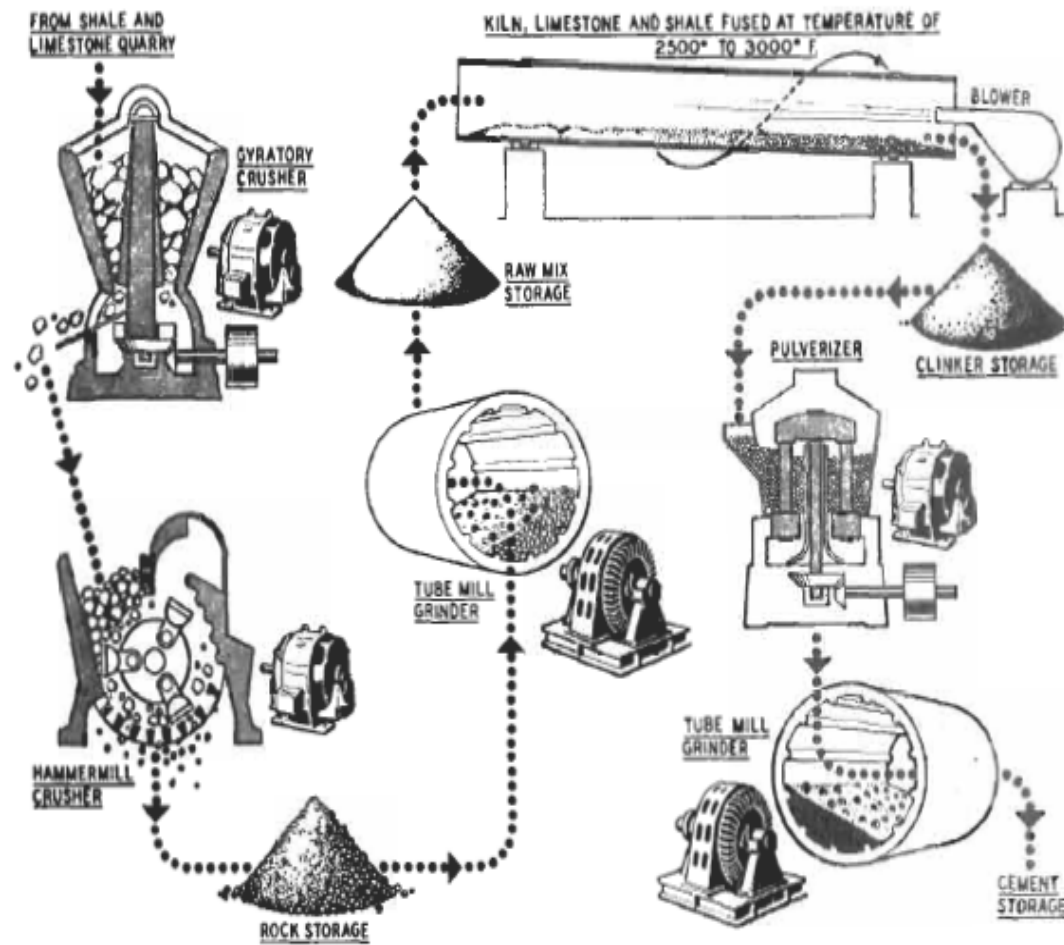

Figure 1-4. Pictorial flow diagram establishes key processing steps: Cement manufacture. By permission, E-M Synchronizer, Electric Machinery Mfg. Co.

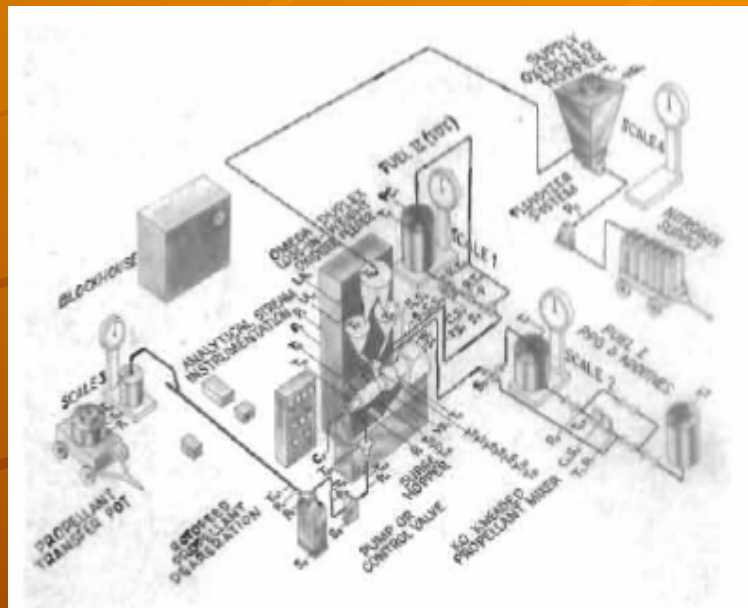

Figure 1-5B. Isometric pictorial flow diagram. By permission, J. W. Keating and R. D. Geckler, Aerojet General Corp.

PFD

TABLE 2.1. Checklist of Data Normally Included on a Process Flowsheet

1. Process lines, but including only those bypasses essential to an understanding of the process
2. All process equipment. Spares are indicated by letter symbols or notes
3. Major instrumentation essential to process control and to understanding of the flowsheet
4. Valves essential to an understanding of the flowsheet
5. Design basis, including stream factor
6. Temperatures, pressures, flow quantities
7. Weight and/or mol balance, showing compositions, amounts, and other properties of the principal streams
8. Utilities requirements summary
9. Data included for particular equipment
 - a. Compressors: SCFM (60°F, 14.7 psia); ΔP psi; HHP; number of stages; details of stages if important
 - b. Drives: type; connected HP; utilities such as kW, lb steam/hr, or Btu/hr
 - c. Drums and tanks: ID or OD, seam to seam length, important internals
 - d. Exchangers: Sqft, kBtu/hr, temperatures, and flow quantities in and out; shell side and tube side indicated
 - e. Furnaces: kBtu/hr, temperatures in and out, fuel
 - f. Pumps: GPM (60°F), ΔP psi, HHP, type, drive
 - g. Towers: Number and type of plates or height and type of packing; identification of all plates at which streams enter or leave; ID or OD; seam to seam length; skirt height
 - h. Other equipment: Sufficient data for identification of duty and size

الگوهای مختلف مورد استفاده در رسم نمودار جریان

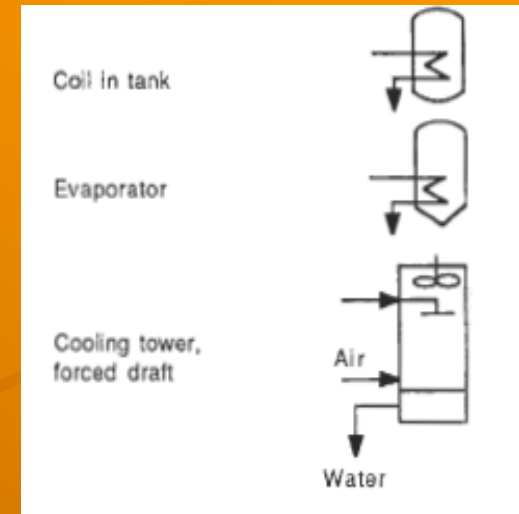
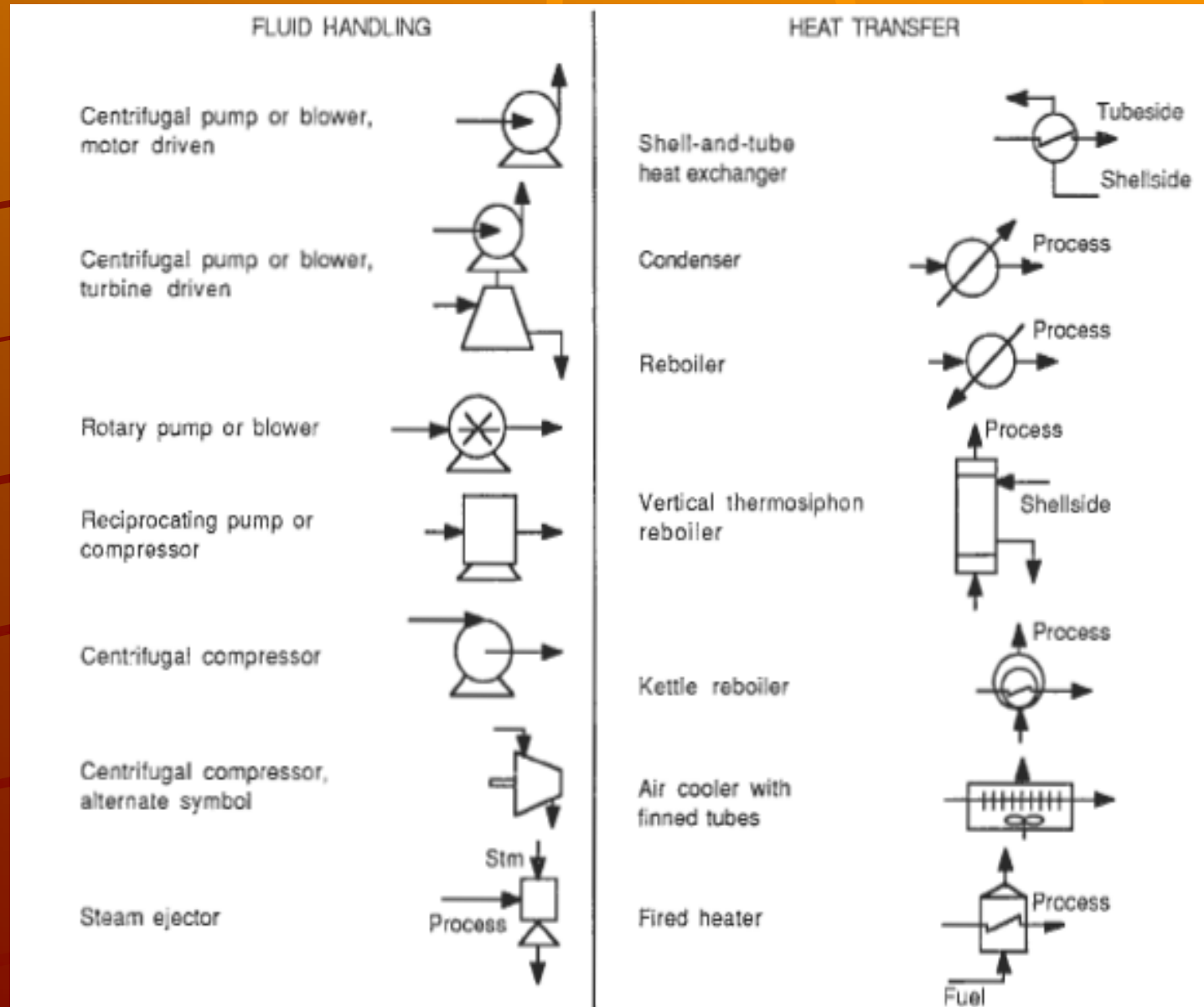

MASS TRANSFER
الگوهای مختلف مورد استفاده در رسم نمودار جریان



Tray column

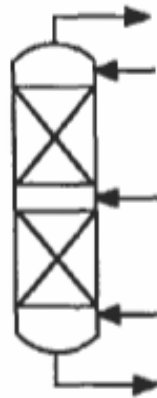

Packed column

www.mblastsavior.mihanblog.com

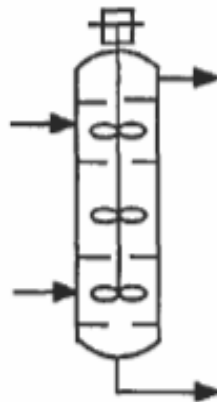

Multistage stirred column

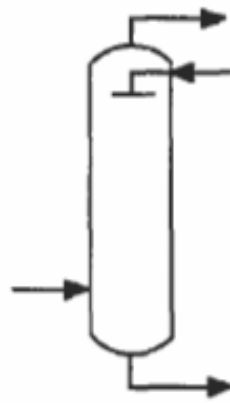

spray column

VESSELS

Drum or tank



Drum or tank



Storage tank



Open tank



Gas holder



Jacketed vessel with agitator

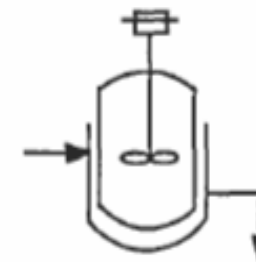



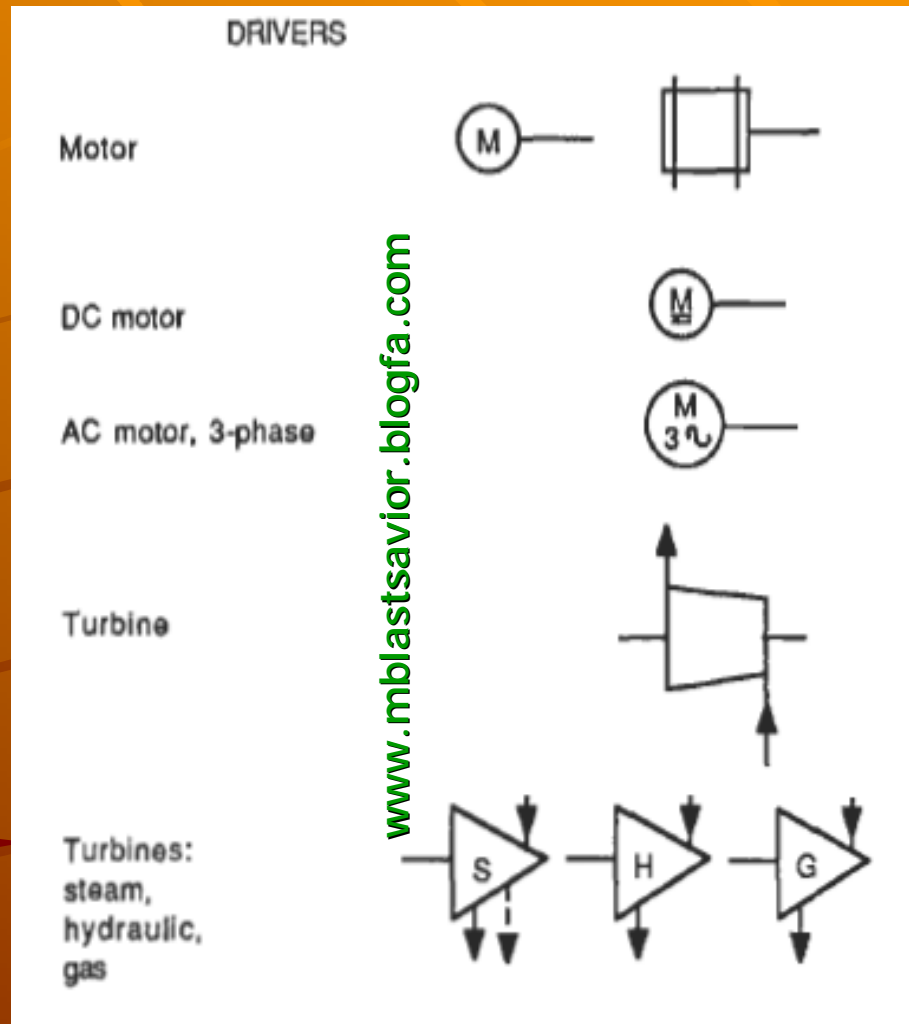



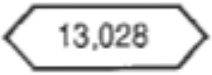

الگوهای مختلف مورد استفاده در رسم نمودار جریان

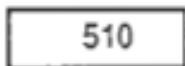

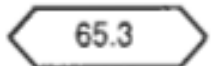
الگوهای مختلف مورد استفاده در رسم نمودار جریان

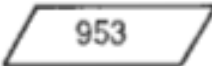
TABLE 2.3. Flowsheet Flags of Operating Conditions in Typical Units

Mass flow rate, lbs/hr		13,028
Molal flow rate, lbmols/hr		217
Temperature, °F		510
Pressure, psig (or indicate if psia or Torr or bar)		155 psia
Volumetric liquid flow rate, gal/min.		65.3
Volumetric liquid flow rate, bbls/day		8,500
Kilo Btu/hr, at heat transfer equipment		9,700
Enthalpy, Btu/lb		953
Others		

1. VISBREAKER OPERATION

Visbreaking is a mild thermal pyrolysis of heavy petroleum fractions whose object is to reduce fuel production in a refinery and to make some gasoline.

The oil of 7.2 API and 700°F is supplied from beyond the battery limits to a surge drum F-1. From there it is pumped with J-1A&B to parallel furnaces B-1A&B from which it comes out at 890°F and 200 psig. Each of the split streams enters at the bottom of its own evaporator T-1A&B that has five trays. Overheads from the evaporators combine and enter at the bottom of a 30-tray fractionator T-2. A portion of the bottoms from the fractionator is fed to the top trays of T-1A&B; the remainder goes through exchanger E-5 and is pumped with J-2A&B back to the furnaces B-1A&B. The bottoms of the evaporators are pumped with J-4A&B through exchangers E-5, E-3A (on crude), and E-3B (on cooling water) before proceeding to storage as the fuel product.

A side stream is withdrawn at the tenth tray from the top of T-2 and proceeds to steam stripper T-3 equipped with five trays. Steam is fed below the bottom tray. The combined steam and oil vapors return to T-2 at the eighth tray. Stripper bottoms are pumped with J-6 through E-2A (on crude) and E-2B (on cooling water) and to storage as "heavy gasoline."

Overhead of the fractionator T-2 is partially condensed in E-1A (on crude) and E-1B (on cooling water). A gas product is withdrawn overhead of the reflux drum which operates at 15 psig. The "light gasoline" is pumped with J-5 to storage and as reflux.

Oil feed is 122,480 pph, gas is 3370, light gasoline is 5470, heavy gasoline is 9940, and fuel oil is 103,700 pph.

Include suitable control equipment for the main fractionator T-2.

Example

UTILITY FLOWSHEETS

UFD (UTILITY FLOW DIAGRAM)

UHD (UTILITY HEADER DIAGRAM)

- ✦ These are P&I diagrams for individual utilities such as **steam, steam condensate, cooling water, heat transfer media** in general, compressed air, fuel, refrigerants, and inert blanketing gases,

P&ID

ENGINEERING FLOWSHEET OR ENGINEERING LINE DIAGRAM

+ BS1646

Piping Symbols

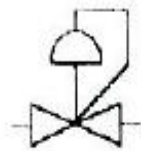

Regulating Valve



Pressure Safety Valve



Spectacle Blind



Rupture Disk

www.mblastsavior.mihanblog.com

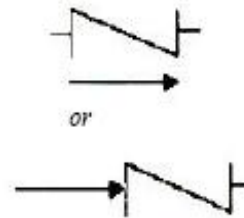

Check Valve

or



Flanged Connection



Reducer



Drain



Expansion Joint

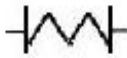

Instrument Symbols

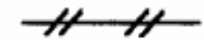

Pneumatic Signal



Electronic Signal



Direct Connection



Thermocouple Wire



Solenoid



Flow Indicator (Rotometer)



Flow Indicator (Gauge)



Orifice Plate



Interlock



Input/Output Card

(s = A for Analog or D for Digital)
(d = I for Input or O for Output)



Relay Function



Mounted Local to Equipment

(v = Sensor Type)
(n = Loop Number)

Mounted on Control Center Panel



Front of Panel

Back of Panel

Mounted on Equipment Panel



Front of Panel

Back of Panel

Note: Displayed on Operator Center CRT with Digital Controls

www.mblastsavior.mihanblog.com

Instrument Identification

Process Variable
(first position of name)

Device
(second position of name;
MODE: F=field, P=panel)

Qualifiers
(last position)

www.mblastsavior.mihanblog.com

<u>Symbol</u>	<u>Description</u>	<u>Symbol</u>	<u>Mode</u>	<u>Description</u>	<u>Symbol</u>	<u>Description</u>
C	Consistency	R	R,P	Recorder	H	High
F	Flow	I	F,P	Indicator	L	Low
T	Temperature	C	F,P	Controller	HH	High High
P	Pressure	RC	F,P	Recording Controller	LL	Low Low
dP	Differential Pressure	IT	F	Indicating Transmitter		
L	Level	S	F	Switch		
S	Speed	E	F	Element		
PN	Position	A	O	Alarm (F-O-P)		
PH	pH Analysis	Y	P	Relay (B-O-P)		
XM	Axial Motion	EY	F	Solenoid		

Special

TW	Thermowell
S.P.	Set Point
ESD	Emergency Shut-Down

Examples:

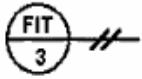

Local flow indicating transmitter, pneumatic; Loop No. 3.

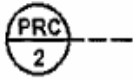

Pressure recording controller, electronic, mounted on panel; displayed, if digital at Loop No. 2.

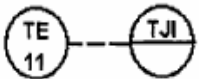

Thermocouple element, local to equipment, connected via thermocouple wire to multipoint temperature indicator mounted on panel; displayed, if digital at Loop No. 11.



تهیه کننده: محمد بهزادی



Analysis (composition) controller, transmitter



Differential pressure controller, transmitter



Flow rate controller, transmitter



Liquid level controller, transmitter



Pressure controller, transmitter



Temperature controller, transmitter

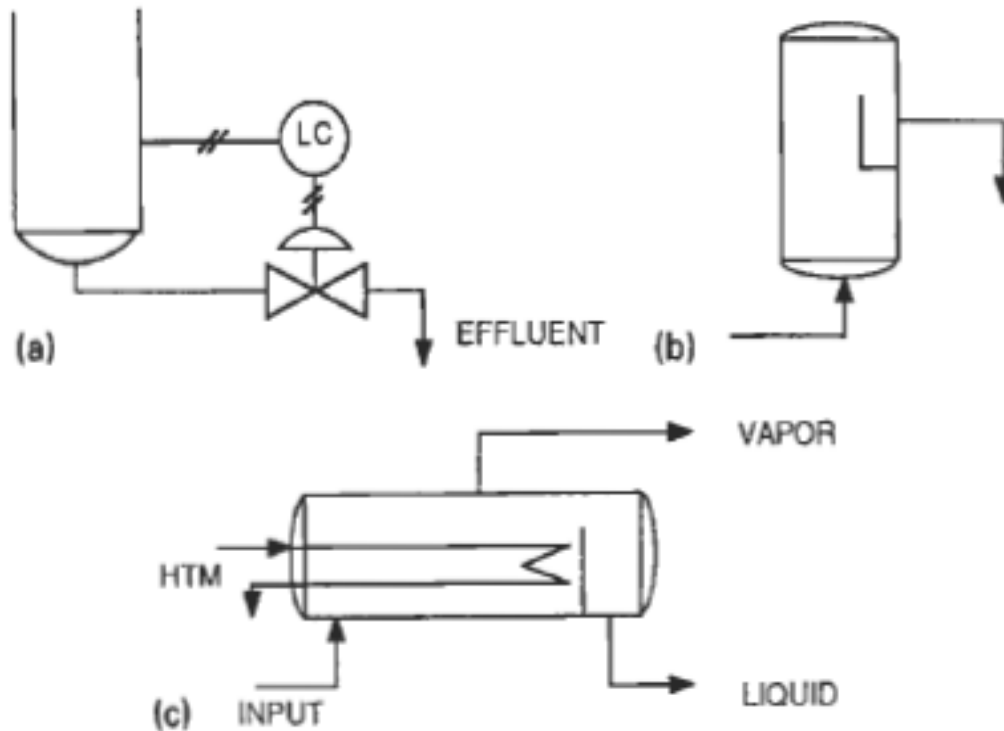

Figure 3.6. Some modes of control of liquid level. (a) Level control by regulation of the effluent flow rate. This mode is externally adjustable. (b) Level control with built in overflow weir. The weir may be adjustable, but usually only during shutdown of the equipment. (c) Overflow weir in a horizontal kettle reboiler. The weir setting usually is permanent.

IPS

PFD – P&ID



Process Flow Diagram

- ◆ These preparation stages describe the following three main phases which can be distinguished in every project & include, but not be limited to:
- ◆ Phase I: Basic Design Stages (containing seven Standards)
- ◆ Phase II: Detailed Design, Engineering and Procurement Stages (containing two Standards)
- ◆ Phase III: Start-Up Sequence and General Commissioning Procedures (containing two Standards)

Phase I: Basic Design Stages (containing 7 Standards)

<u>STANDARD CODE</u>	<u>STANDARD TITLE</u>
✦ <u>I) Manuals of Phase I (Numbers 1 - 7)</u>	
✦ <u>IPS-E-PR-150</u>	"Basic Design Package"
✦ <u>IPS-E-PR-170</u>	"Process Flow Diagram"
✦ <u>IPS-E-PR-190</u>	"Layout and Spacing"
✦ <u>IPS-E-PR-200</u>	"Basic Engineering Design Data"
✦ <u>IPS-E-PR-230</u>	"Piping & Instrumentation Diagrams (P&IDs)"
✦ <u>IPS-E-PR-250</u>	"Performance Guarantee"
✦ <u>IPS-E-PR-308</u>	"Numbering System"

Phase II: Detailed Design, Engineering and Procurement Stages (containing 2 Standards)

- ✦ I) Manuals of Phase II (Numbers 8&9)
- ✦ IPS-E-PR-260 "Detailed Design, Engineering and Procurement"
- ✦ IPS-E-PR-300 "Plant Technical and Equipment Manuals (Engineering Dossiers)"

Phase III: **Start-Up** Sequence and General Commissioning Procedures (containing two Standards)

- ✦ III) Manuals of Phase III (Numbers 10&11)
- ✦ IPS-E-PR-280 "Start-Up Sequence and General Commissioning Procedures"
- ✦ IPS-E-PR-290 "Plant Operating Manuals"

Scope

- ✦ This Standard is also intended to establish uniform symbols for equipment, piping and instrumentation on P&IDs and UDFDs throughout the Oil, Gas and Petrochemical (OGP) projects.

Flowsheets

- ✦ the Piping and Instrumentation Diagrams (P&IDs)
- ✦ Utility Distribution Flow Diagrams (UDFDs,UHD,UFD)
- ✦ Process flow diagram(PFD)



REFERENCES

- ◆ ASME (AMERICAN SOCIETY OF MECHANICAL ENGINEERS)

- ◆ ASME Code.

- ◆ ANSI (AMERICAN NATIONAL STANDARD INSTITUTE)

- ◆ ANSI B 16.1 "Cast Iron Pipe Flanges and Flanged Fittings, Class 25, 125, 250 and 800"

- ◆ 1st. Ed., 1989

- ◆ IPS (IRANIAN PETROLEUM STANDARDS)

- ◆ IPS-E-PR-200 "Basic Engineering Design Data"

- ◆ IPS-E-PR-308 "Numbering System"

- ◆ IPS-E-PR-725 "Process Design of Plant Waste Sewer Systems"

- ◆ IPS-G-IN-160 "Control Valves"

- ◆ IPS-D-AR-010 "Abbreviations & Symbols for HVAC&R Drawings"

- ◆ IPS-D-AR-011 "General Notes for HVAC & R System"

REFERENCES

- ◆ ISA (INSTRUMENT SOCIETY OF AMERICA)
- ◆ ISA-S5.1 "Instrumentation Symbols and Identification" 1st. Ed., 1984
- ◆ ISA-S5.2 "Binary Logic Diagrams for Process Operations" 2nd. Ed., 1981 (Reaffirmed 1992)
- ◆ ISA-S5.3 "Graphic symbols for distributed control / shared display instrumentation, logic and computer systems "Ed.,1983
- ◆ ISA-S5.4 "Instrument Loop Diagrams" Ed., 1991
- ◆ ISA-S5.5 "Graphic Symbols for Process Displays" 1st. Ed., 1985
- ◆ ISA-S18.1 "Annunciator Sequences and Specifications" 1st. Ed., 1979 (Reaffirmed 1992)
- ◆ ISA-S50.1 "Compatibility of analogue signals for electronic industrial process instruments" 1st. Ed., 1975 (Reaffirmed 1995)
- ◆ ISA-S51.1 "Process Instrumentation Terminology" 1st. Ed., 1979

REFERENCES

- ✦ ISO (INTERNATIONAL ORGANIZATION FOR STANDARDIZATION)
- ✦ ISO 3098: Part 1 "Technical Drawings-Lettering, Part 1: Currently Used Characters"
1st. Ed. 1974
- ✦ ISO 3511: Part 1 & Part 4 "Process measurement control functions and instrumentation-symbolic representation-Part 1: Basic requirements, 1st.Ed. 1977;Part 4: Basic symbols for process computer, Interface, and shared display/control functions" Ed. 1985
1st. Ed., 1984
- ✦ ISO 6708 "Pipe component definition of nominal size" Ed., 1995.
- ✦ API (AMERICAN PETROLEUM INSTITUTE)
- ✦ API Standard 602 "Compact steel gate valves-flanged, threaded, welding and extended body ends "nine Ed., 1995
- ✦ GPSA (Gas Process System Analysis)

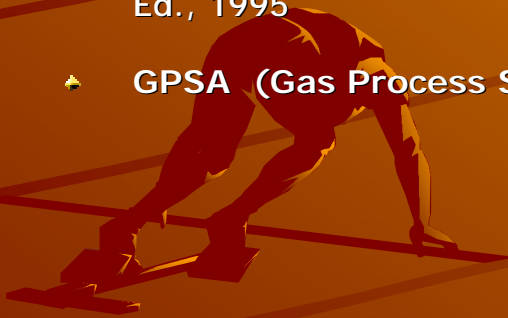

TERMINOLOGY:

- ◆ **Company or Employer/Owner :**
 - affiliated companies of the Iranian ministry of petroleum :
 - ◆ National Iranian Oil Company (NIOC)
 - ◆ National Iranian Gas Company (NIGC)
 - ◆ National Petrochemical Company (NPC)



SYMBOLS AND ABBREVIATIONS

Drain / Sewer Symbols

n	AMN	Amine Drains (MEA,MDEA)
n	AY	Amine Drain Funnel (MEA,MDEA)
n	CAU	Caustic Sewer(NAOH)
n	CDB	Concrete Drain Box
n	CSW	Chemical Sewer
n	CY	Chemical Drain Pit
n	DC	Drain Connection
n	DWW	Desalter Waste Water
n	NSW	Non Oily Water Sewer
n	OPD	Open Drain
n	OSW	Oily Water Sewer
n	SSW	Sanitary Water Sewer
n	SWA	Stripped Sour Water
n	TY	Toxic Drain Funnel
n	Y	Drain Funnel (General)

Letters at Individual Valves Designations

n	B	Monel Valve (grease sealed seat and packing)
n	BV	Ball Valve
n	CAO	Close-Automatic-Open
n	CC	Cable Control
n	CO	Chain Operated
n	CHV	Check Valve
n	D	Drain
n	FB	Full Bore
n	FC	Fail Close (closes on minimum signal to valve actuator)
n	FO	Fail Open (opens on minimum signal to valve actuator)
n	FD	Flex Disc Valve (Diapheragm Valve)

Monel الياژی از نیکل و کبالت که در برابر خوردگی مقاوم است

Flex خم شو

Letters at Individual Valves Designations

n	MOV	Motorized Valve
n	NC	Normally Closed
n	NO	Normally Open
n	NV	Needle Valve (Plug valve)
n	OV	Operating Valve
n	PIVA	Post Indicator Valve(if it is Closed or open)
n	PSE	Rupture Disk Assembly (Pressure Safety Equipment)
n	PSV	Pressure Safety Relief Valve
n	P	Plugged
n	SR	Split Range
n	SSV	Stainless Steel Valve
n	T	Trap
n	V	Vent
n	WP(J)	Jacketed Plug Valve
n	XCV	Steam Trap with Integral Strainer

Piping Abbreviations

n	CS	Carbon Steel
n	DN	Diameter Nominal
n	FF	Flat Face
n	FS	Forged Steel
n	LJ	Lap Joint
n	MI	Malleable Iron
n	PN	Pressure Nominal
n	RF	Raised Face
n	RS	Removable Spool
n	SF	Socket Weld Line Blind with Flexitallic Gaskets
n	SB	Spectacle Blind
n	SO	Slip on
n	SS	Stainless Steel
n	ST(H)	Steam Trap (Heat Conservation)
n	SW	Socket Weld
n	WN	Weld Neck

Miscellaneous Designations

n	AG	Above Ground
n	BL	Battery Limit
n	DCS	Distributed Control System
n	HCB	Hydrocarbon
n	HCH	Hydrocarbon with Hydrogen
n	HHLL	High High Liquid Level
n	HLL	High Liquid Level
n	LG	Level Gage
n	LLL	Low Liquid Level
n	LLLL	Low Low Liquid Level
n	MW	Manway
n	NLL	Normal Liquid Level
n	P	Pressure
n	PB	Push Bottom
n	PFD	Process Flow Diagram
n	PG	Pressure Gage
n	PI	Pressure Indicator

Miscellaneous Designations

n	P&ID	Piping & Instrumentation Diagram
n	PO	Pump Out
n	PT	Pressure Test Connection
n	RES	Residue
n	RG	Refrigerant Gas
n	RL	Refrigerant Liquid
n	RTD	Resistance Temperature Detector
n	RVP	Reid Vapor Pressure
n	SC	Sample Connection
n	SCL	Sample Cooler
n	SG	Sight Glass
n	SP	Set Point
n	SP.GR.	Relative Mass Density (Specific Gravity)
n	STO	Steam Out
n	TI	Temperature Indicator
n	T/T	Tangent to Tangent
n	UFD	Utility Flow Diagram
n	UG	Under Ground
n	VB	Vortex Breaker

Utility Services Abbreviations

n	BFW	Boiler Feed Water
n	CLW	Chlorinated Water
n	CW	Cooling Water
n	CWR	Cooling Water Return
n	CWS	Cooling Water Supply
n	DMW	Demineralized Water
n	DSW	Desalinated Water
n	DWA	Drinking Water
n	FLG	Fuel Gas
n	FLR	Flare Discharge
n	FOR	Fuel Oil Return
n	FOS	Fuel Oil Supply
n	FWA	Fire Water
n	HBW	High Pressure Boiler Feed Water
n	HPC	High Pressure Condensate
n	HPS	High Pressure Steam

Utility Services Abbreviations

n	ISA	Instrument Air
n	LLPS	Low Low Pressure Steam
n	LPC	Low Pressure Condensate
n	LPS	Low Pressure Steam
n	MBW	Medium Pressure Boiler Feed Water
n	MPC	Medium Pressure Condensate
n	MPS	Medium Pressure Steam
n	NG	Natural Gas
n	NIT	Nitrogen
n	PLA	Plant Air
n	PWA	Plant Water(service water)
n	RFO	Refinery Fuel Oil
n	RFW	Refrigerated water
n	RWA	Raw Water
n	SWA	Sour Water
n	TWA	Treated Water
n	WAT	Water

power supply

n AS Air Supply

n ISA Instrument Air

n PLA Plant Air

n ES Electric Supply

n GS Gas Supply

n HS Hydraulic Supply(Water)

n NS Nitrogen Supply

n SS Steam Supply

SYMBOL

DESCRIPTION



Main process line (arrow of 30 indicates Direction of fluid flow)

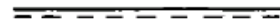

Heat traced pipe line



Underground pipeline

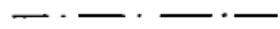

Existing line



Future line



Vendor package



Jackated or double containment pipeline



Line crossing (connected)

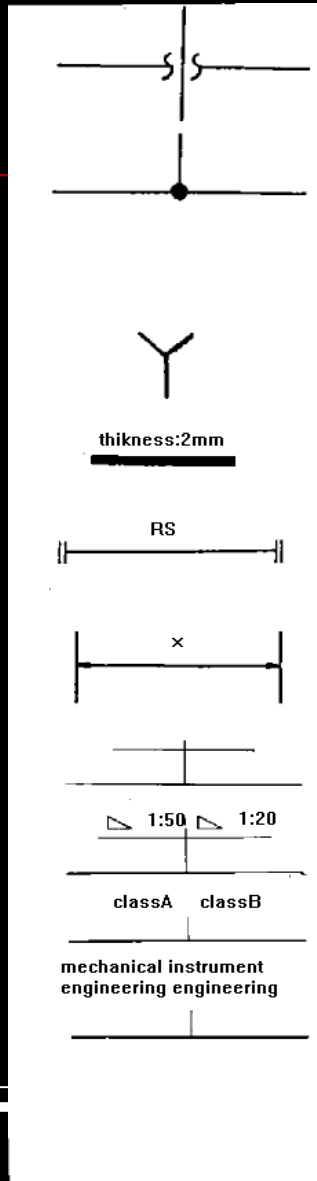

n Line crossing (nconnected)

n Lines junction

n Dripe funnel

n Platform

n Removable spoolpice

n Minimum distance

n Indication of point of change:

n a)change in sloop

n b) change in piping class

n c)change in responsibility

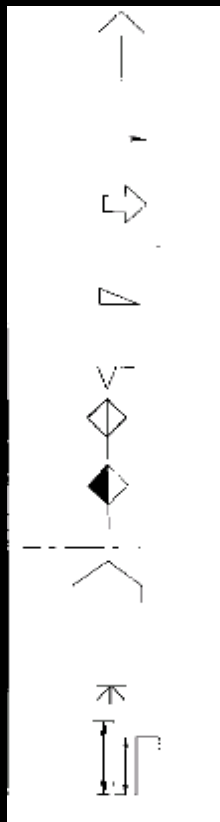





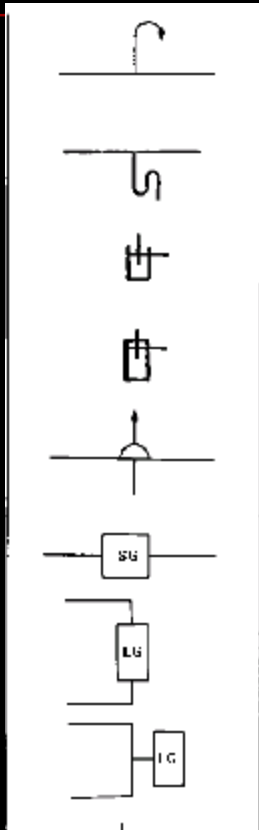

- n Outlet to the atmosphere for steam / gas
- n Flow / motion in diraction of arrow
- n Arrow for inlet or outlet of essential substances

- n Slope
- n Level reference
- n Limit , general
- n Contractor/ vendor
- n Battery limit
- n Hood , general (Furnace)
- n Distribution device for fluids , spray nozzle
- n Siphon with dip length



- n Open vent
- n Syphon drain(seal leg)
- n Liquid seal, oen
- n Liquid seal ,closed
- n Butsting disc
- n Sight glass
- n Level gage
- n Level gage on standpipe (vertical pipe)

Interlock logic symbols

symbol	description
 or	output exists if one or more input exists
 and	output exists if and only if all the input exists
 not	no output exists if one and only one input exists
 td	time delay output exists after preset time
 exclusive	output exists if one and only one input exists
	sequential logic control connection

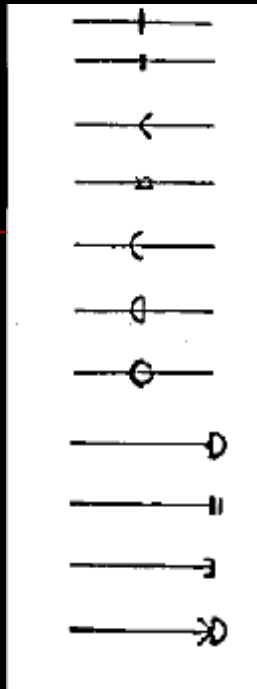

- n Butt welded joint
- n Flanged joint
- n Screwed joint (arrow : 90)
- n Socket welded joint
- n Socket and spigot joint
- n Compression joint
- n Swivel joint
- n End cap ,but welded
- n End flanged and bolted
- n End cap ,fillet welded (socket)
- n End cap ,screwed (arrow:90)

Symbols for manually operated and miscellaneous valves and monitors

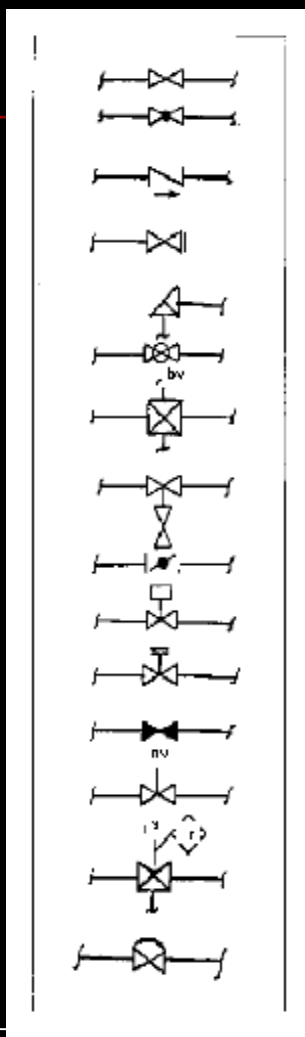

- n Gate valve (basic symbol)
- n Globe valve
- n Check valve (general)
- n Gate valve behind off
- n Angle valve
- n Ball valve
- n Fourway valve

- n Gate valve with body bleed
- n Butterfly valve
- n Hydraulic control (water force)
- n Metering cock
- n Needle valve
- n Plug valve

- n S=solenoid valve
- n R= Manual reset when indicated
- n Diaphragm valve

Equipment: Tower, column, vessel and reactor

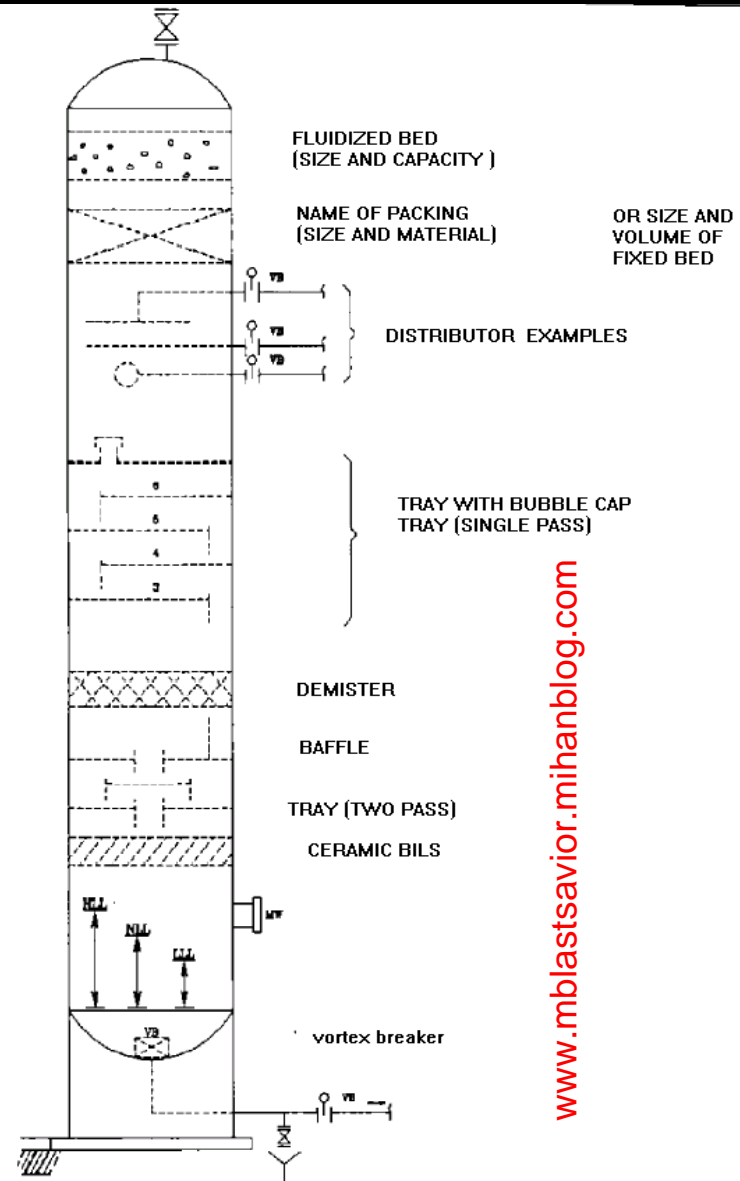

A.2.3.1.2 HORIZONTAL VESSELE

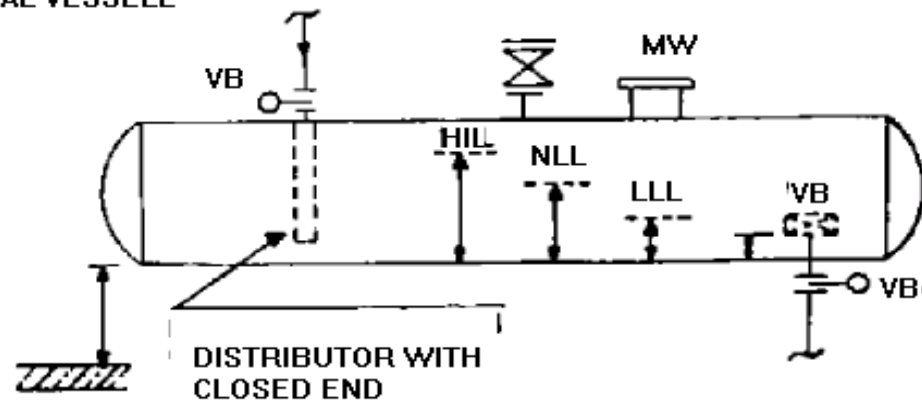

(A) HORIZONTAL VESSELE

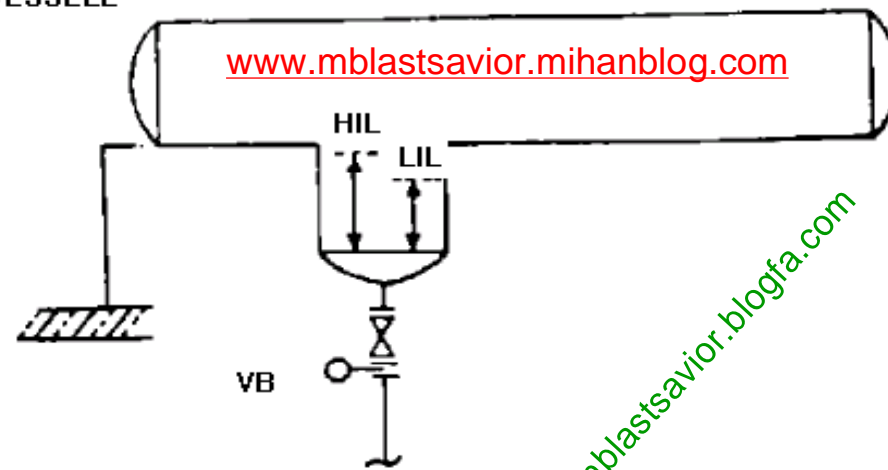

B) HORIZONTAL VESSELE WITH BOOT

Note:

All tanks and spheres on each flow diagram are to be shown in Approximate relative size to each other

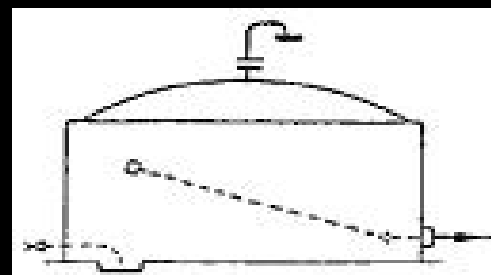

DOME ROOF
WITH SWING PIPE FLOAT TYPE



FLOATING ROOF

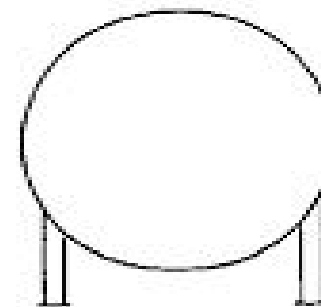

SPHERE

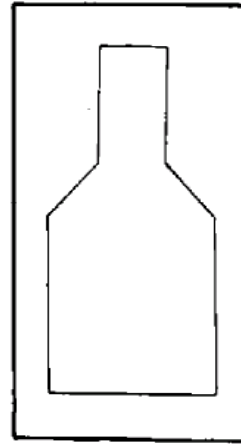

A) FURNACE (BASIC SYMBOL)

www.mblastsavior.mihanblog.com

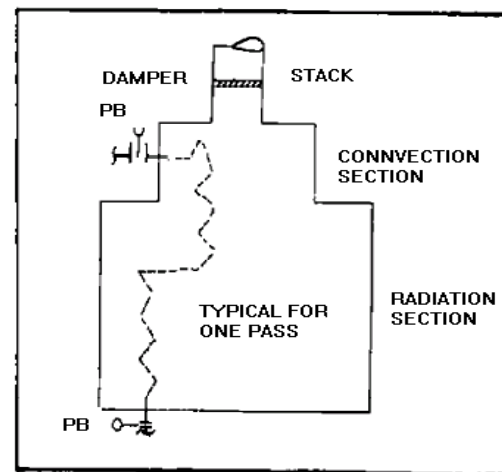

B) FIRED HEATER (BOX OR CYLINDERICAL TYPE) WITH COVECTION SECTION

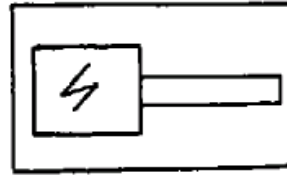

C) ELECTRICAL HEATER

www.mblastsavior.mihanblog.com

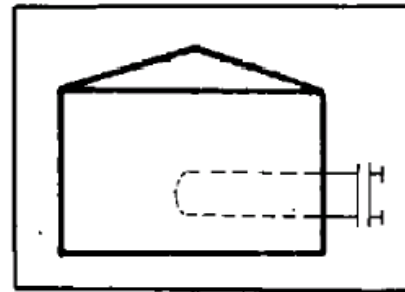

D) TANK HEATER

www.mblastsavior.blogfa.com

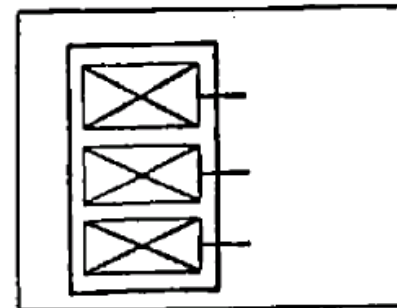
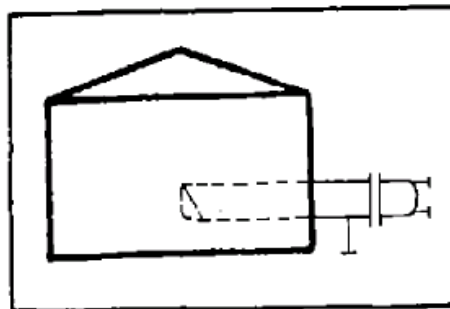

A.2.3.3.2 exchangers water coolers and reboilers

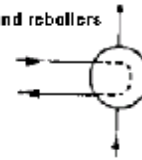

shell and tube heat exchanger(basic symbol)

	heat exchanger/cooler/condenser , with floating head
	heat exchanger/cooler/condenser u tube
	heat exchanger/cooler/condenser fixed tube sheet
	cooler/ condenser with floating head and cover plate
	horizontal reboiler fixed tube sheet
	kettle type reboiler u-tube
	kettle type vaporizer floating head
	kettle type vaporizer fixed tube sheet

Air coolers

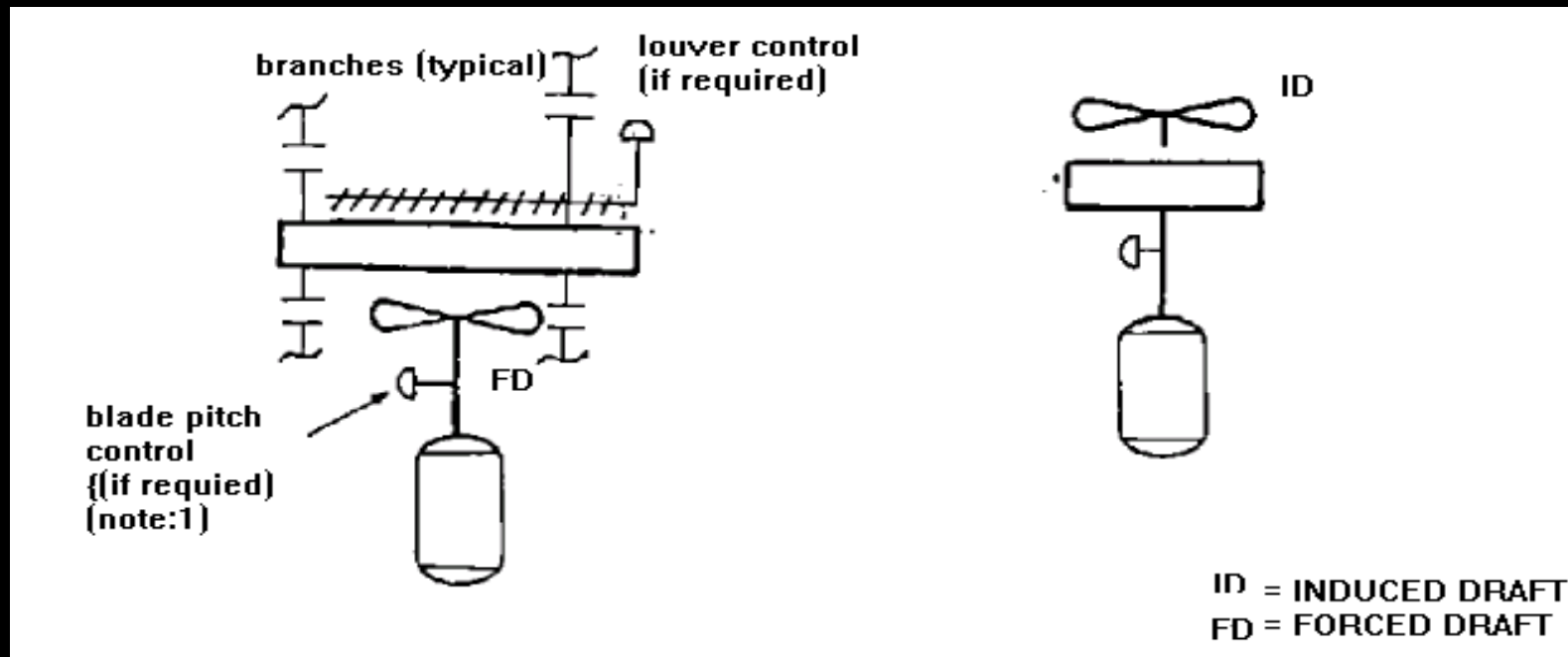

Pumps

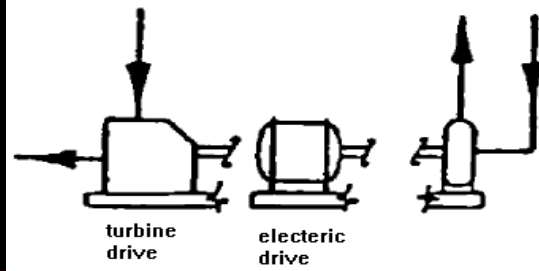

centrifugal pump

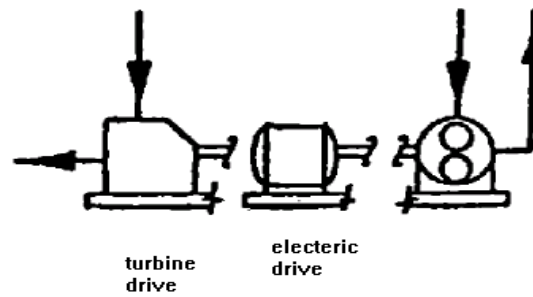

rotary pump
(gear pump)

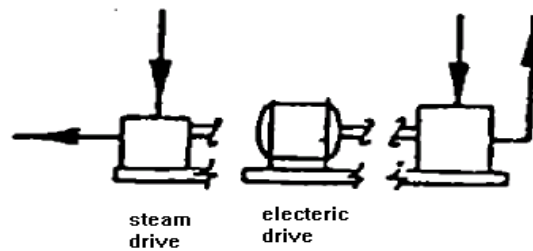

reciprocating pump

NOZZLES IDENTIFICATIONS ON VESSELS, REACTORS AND TOWERS

<u>NOZZLE</u>	<u>IDENTIFICATION SYMBOL</u>
A,A2	Inlets
B	Outlet
C	Condensate
D	Drain or Draw-off
E*	
F	Feed
G	Level gage or gage glass
H	Handhold
J	Pumpout
K*	
L	Level instrument (also LT, LI)
M	Manhole
N	Reboiler connection
P	Pressure connection (also PT, PI)
R	Reflux
S	Steam or sample connection
T	Temperature connection (also TI, TE, TW)
V	Vapor or vent
W	Relief valve connection
	(Oversize unless actual size known)
*Use E or K when non of the other symbols apply. Do not use I, O, Q, U, X, Y, or Z.	

اصطلاحات
متفاوت با
معانی
یکسان در
زبانهای
انگلیسی و
آمریکایی

Different words are used, in different countries, to describe the same job or piece of equipment. Some of the principal differences between the United States and the United Kingdom are listed here. Within each country, however, there are differences between companies.

www.mblastsavior.mihanblog.com

Management Terms

Job	U.S.	UK
Operator of plant	Operator	Process worker
Operator in charge of others	Lead operator	Chargehand or Assistant foreman or Junior supervisor
Highest level normally reached by promotion from operator	Foreman	Foreman or Supervisor
First level of professional management (usually in charge of a single unit)	Supervisor	Plant manager
Second level of professional management	Superintendent	Section manager
Senior manager in charge of site containing many units	Plant manager	Works manager
Plant personnel	Craftsman or mechanic	Fitter, electrician, etc.

اصطلاحات
متفاوت با
معانی
یکسان در
زبانهای
انگلیسی و
آمریکایی

The different meanings of the terms *supervisor* and *plant manager* in the U.S. and UK should be noted.

In this book I have used the term *foreman* as it is understood in both countries, though its use in the UK is becoming outdated. *Manager* is used to describe any professionally qualified person in charge of a unit or group of units. That is, it includes people who, in many U.S. companies, would be described as supervisors or superintendents.

Certain items of plant equipment have different names in the two countries. Some common examples are:

Chemical Engineering Terms

U.S.	UK
Accumulator	Reflux drum
Agitator	Mixer or stirrer
Air masks	Breathing apparatus (BA)
Blind	Slip-plate
Carrier	Refrigeration plant
Cascading effects	Knock-on (or domino effects)
Check valve	Nonreturn valve
Clogged (of filter)	Blinded
Consensus standard	Code of practice
Conservation vent	Pressure/vacuum valve
Dike, berm	Bund
Discharge valve	Delivery valve
Division (in electrical area classification)	Zone
Downspout	Downcomer
Expansion joint	Bellows
Explosion proof	Flameproof
Faucet	Tap
Fiberglass-reinforced plastic (FRP)	Glass-reinforced plastic (GRP)
Figure-8 plate	Spectacle plate
Flame arrestor	Flame trap
Flashlight	Torch
Fractionation	Distillation
Gasoline	Petrol
Gauging (of tanks)	Dipping
Generator	Dynamo or alternator
Ground	Earth
Horizontal cylindrical tank	Bullet
Hydro (Canada)	Electricity
Install	Fit
Insulation	Lagging
Interlock*	Trip*
Inventory	Stock
Lift-truck	Forklift truck
Loading rack	Gantry

اصطلاحات متفاوت با معانی یکسان در زبانهای انگلیسی و آمریکایی

اصطلاحات متفاوت با معانی یکسان در زبانهای انگلیسی و آمریکایی

U.S.	UK
Manway	Manhole
Mill water	Cooling water
Nozzle	Branch
OSHA (Occupational Safety and Health Administration)	Health and Safety Executive
Pedestal, pier	Plinth
Pipe diameter (internal)	Pipe bore
Pipe rack	Pipebridge
Plugged	Choked
Rent	Hire
Rupture disc or frangible	Bursting disc
Scrutinize	Vet
Seized (of a valve)	Stuck shut
Shutdown	Permanent shutdown
Sieve tray	Perforated plate
Siphon tube	Dip tube
Spade	Slip-plate
Sparger or sparge pump	Spray nozzle
Spigot	Tap
Spool piece	Bobbin piece
Stack	Chimney
Stator	Armature
Tank car	Rail tanker or rail tank wagon
Tank truck	Road tanker or road tank wagon
Torch	Cutting or welding torch
Tower	Column
Tow motor	Forklift truck
Tray	Plate
Turnaround	Shutdown
Utility hole	Manhole
Water seal	Lute
Wrench	Spanner
C-wrench	Adjustable spanner
Written note	Chit

اصطلاحات متفاوت با معانی یکسان در زبانهای انگلیسی و آمریکایی

\$M	Thousand dollars
\$MM	\$M or million dollars
STP	60°F, 1 atmosphere
32°F, 1 atmosphere	STP
NTP	32°F, 1 atmosphere

**In the UK, interlock is used to describe a device that prevents someone opening one valve while another is open (or closed). Trip describes an automatic device that closes (or opens) a valve when a temperature, pressure, flow, etc., reaches a preset value.*

www.mblastsavior.mihanblog.com

Fire-Fighting Terms

U.S.	UK
Dry chemical	Dry powder
Dry powder	Dry powder for metal fires
Egress	Escape
Evolutions	Drills
Excelsior (for fire tests)	Wood wool
Fire classification:	
Class A: Solids	Class A: Solids
Class B: Liquids and gases	Class B: Liquids
Class C: Electrical	Class C: Gases
Class D: Metals	Class D: Metals
Fire stream	Jet
Nozzle	Branchpipe
Standpipe	Dry riser
Tip	Nozzle
Wye connection	Dividing breeching

Numbering System

بر مبنای IPS



- | instrumentation identifications
- | equipment abbreviations (codes)
- | fluid abbreviations
- | painting, insulation and heat tracing designations.

SCOPE

- I numbering for instrument and electrical equipment, piping line and engineering documents such as specifications, purchase orders, and other facilities.

REFERENCES

I ISA (INSTRUMENT SOCIETY OF AMERICA)

- I S 5.1-1984. "Instrumentations Symbol and Identification Formerly", Ed. 1989

I ISO (INTERNATIONAL ORGANIZATION FOR STANDARDIZATION)

- I 6708-1995 (E) "Pipe Components Definition and Selection of Nominal Size", 2nd. Ed., 1995.

EQUIPMENT NUMBERING SYSTEM

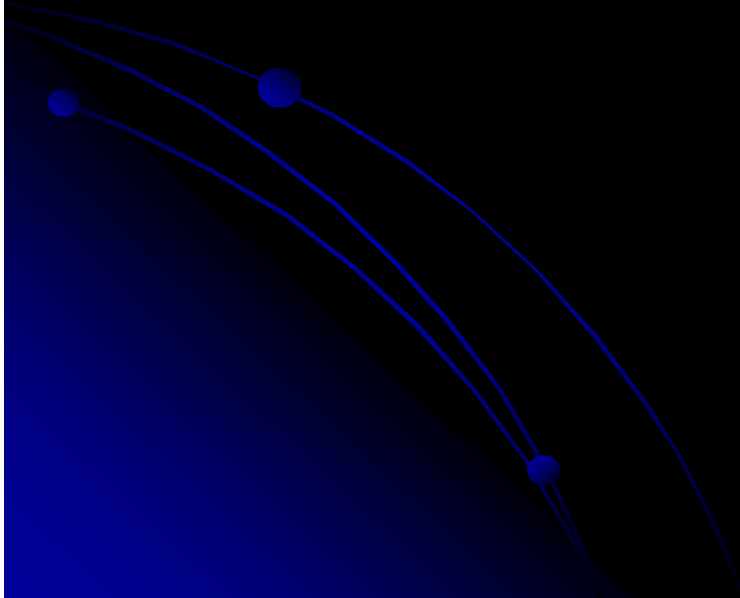

Main Equipment & Package Unit

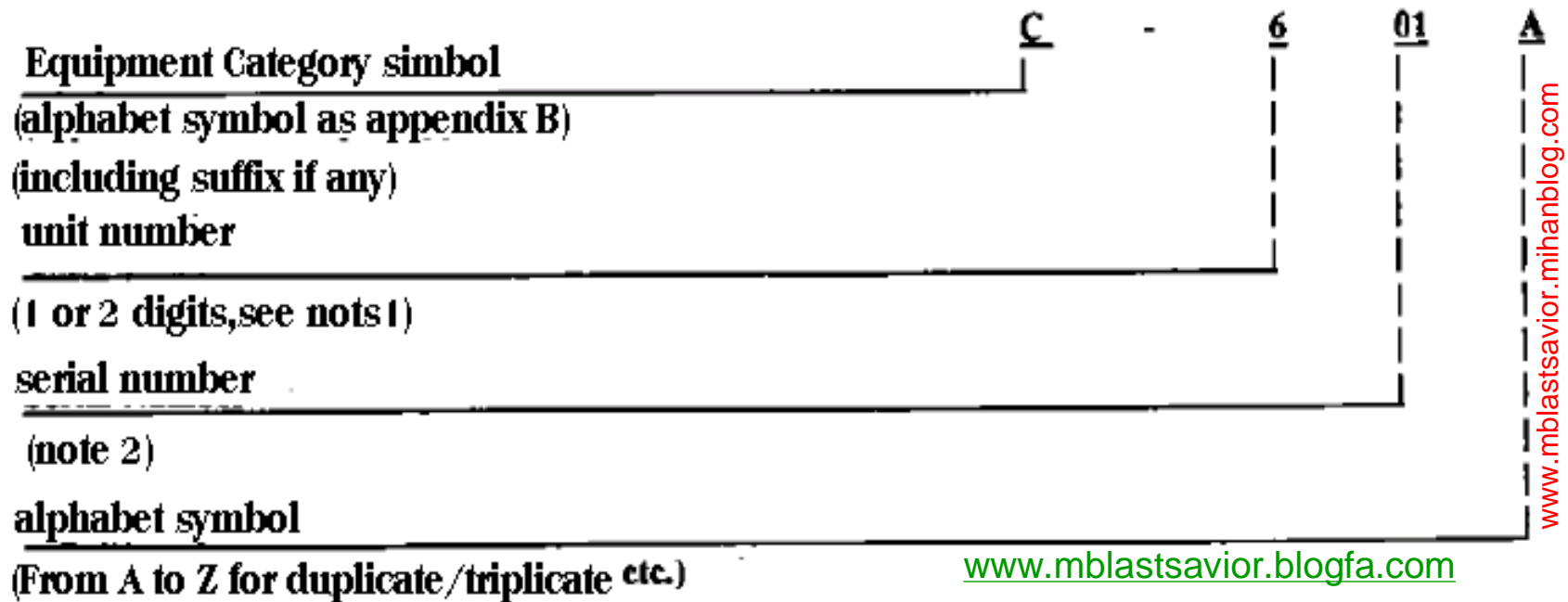

- I Notes:
- I 1) Unit number for the equipment shall start from 1 (not from 01). For a typical refinery units see Appendix A.
- I 2) Serial number for equipment including mechanical, machinery, electrical, ancillary facilities, buildings, general items, etc., shall be from 01 to 99 unless otherwise specified. The numbering of instruments and control equipment should be from 001 to 999. For the units with more than one section (e.g., crude and vacuum distillation unit, etc.), equipment serial number to be utilized for each section shall be determined by the Contractor (e.g., from 01 to 50 and from 50 to 99 to crude distillation and vacuum distillation sections respectively).

APPENDIX B EQUIPMENT CATEGORY SYMBOL

AGITATOR	AG
AIR CONDITIONER	AC
BLENDER	BR
COMPRESSOR	C
CONTINUOUS MIXER, PLASTICS	CM
CONTROL PANEL	CPL
CONVEYOR, MECHANICAL OR PNEUMATIC	CV
COOLING TOWER	CT
CRANE	CN
CRUSHER	CR
CRYSTALLIZER	CS
CUTTER	CU
CYCLONE AND HYDROCLONE	CY
DESALTER	DE
EVAPORATOR	EV
EXCHANGER, SHELL-AND TUBE, DOUBLE PIPE, PLATE, COILS, AIR COOLED, REBOILER, BOX COOLER, CASCADE COOLER, SURFACE CONDENSER	E
EXTRUDER	EX

www.mblastsavior.mihanblog.com

APPENDIX B EQUIPMENT CATEGORY SYMBOL

FAN	FA
FILTER	F
FLARE STACK	FST
HEATER, FIRED	H
LOADING ARM	LA
MILL	MI
PUMP	P
REACTOR	R
SAMPLER	SA
SEPARATOR, ATMOSPHERIC	SE
SPECIALITY MOBILE EQUIPMENT, (FIRE TRUCK, SNOW REMOVAL)	SM
STACK, CHIMNEY	S
STEAM TRAP	STP
STRAINER	STR
SUMP	SU
TANK; API, SILO, HOPPER	TK
VALVE, SLIDE (SEE GATE, SLIDE)	SG
VALVE, ROTARY	RV
VALVE, MOTORIZED	MOV
VESSEL, PRESSURE (COLUMN, ACCUMULATOR, K.O. DRUM SPHERE, BULLET) V	

Appendix A

UNIT IDENTIFICATION NUMBER

I for a typical refinery

UNIT No.	ABBREVIATION	UNIT NAME AND DESCRIPTION
00	COMMON	Common (Subject related to all units)
01	CDU/VDU	Crude and Vacuum Distillation Unit (including Atmospheric and Vacuum Distillation, Desalter and Gasoline Stabilizer and Splitter Sections)
02	NHT/CCR	Heavy Naphtha Hydrotreater and Continuous Catalyst Regeneration Platformer Unit
03	VBU	Visbreaker Unit (Visbreaker including Tempered Water System)
05	LPG/CAU	LPG Recovery and Caustic Dissolving Unit
06	HCU	Hydrocracker Unit (HC-Unibon)
07	HPU	Hydrogen Production Unit
08	AMN/SWS	Amine Treating and Sour Water Stripper Unit
09	SRU/SSU	Sulphur Recovery and Sulphur Solidification Unit
10	ABU	Asphalt Blowing Unit
11	NIT	Nitrogen Unit
20	OFF-SITE	Offsite Unit (including Tankage, Blending and Product

APPENDIX A (continued)

www.mblastsavior.mihanblog.com

26	WWT	Waste Water Treatment Unit (including Waste Water Treatment, Evaporation Pond, Sewage Treatment and Disposal)
30	LPG/LOAD	LPG <u>Tankage</u> and Loading Unit
40	ANCILLARY	Ancillary Facilities (including all Ancillary Refinery Building, Civil Works and all general items)
45	INTERCONN	Interconnections

Drivers for Main Equipment

- | Drivers for main equipment shall be numbered as follows:



- | **Note:**
- | **Type of drivers shall be as follows:**
- | **DE : Diesel Engine**
- | **GE : Gas Engine**
- | **GT : Gas Turbine**
- | **HT : Hydraulic Turbine**
- | **M : Electric Motor**
- | **ST : Steam Turbine**
- | **TEX: Turbo Expander.**

PIPING LINE NUMBERING SYSTEM

- ▮ Piping lines shall be numbered in the following manner:
- ▮ Numbering of All Lines Excluding Steam Tracing Spools

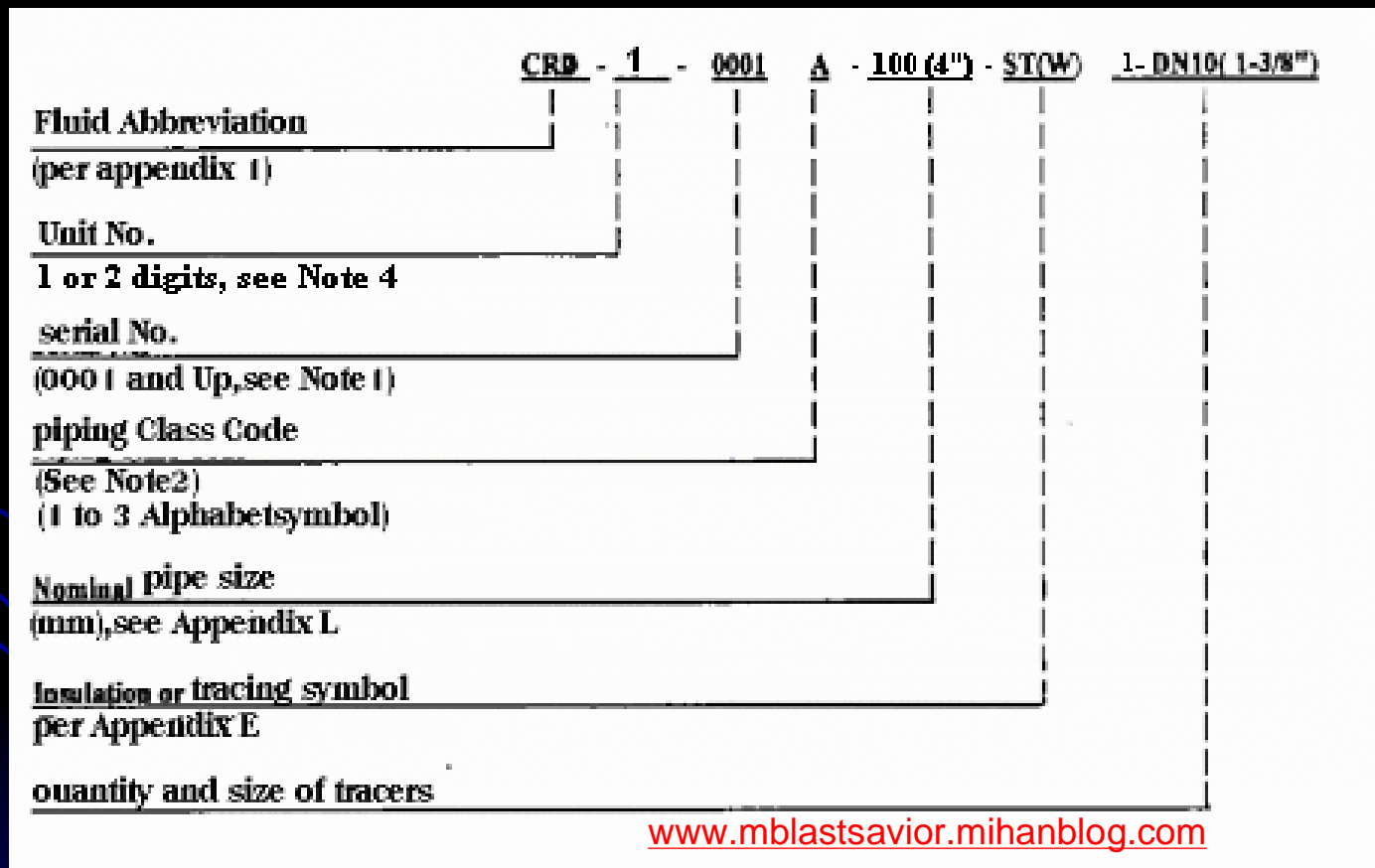

Notes:

- | 1) Piping serial number, in general is started from 0001 and Up except for the units which are characterized by more than one section such as **crude and vacuum distillation** unit. In such cases, split of piping serial numbers to be assigned for each section of the unit shall be determined by the **Contractor**.
- | Special number 7001 : 9999 shall be used for all drains, relief headers and utility services including fuel oil and fuel gas for all units except for the units which are producing the subject utility services.
- | For assigning the piping serial number, the following items should be taken into consideration:
 - | a) The individual line number shall be held up to the point where the line ends at the inlet of equipment such as a vessel, exchanger, pump, etc., an other number is required for the line downstream of the equipment.
 - | b) All utility headers (systems) shall be numbered with their respective units. All branches serving a specific unit will be numbered with that unit.
 - | f) All firewater and sewer branches serving a specific unit shall be numbered.
- | 2) Piping class code shall be in accordance with the line classes utilized in project piping material specification.
- | 3) Piping components not identified by instrument or mechanical equipment numbers, etc., and not covered by the piping material specification, are identified by a special item number.
- | 4) Unit number of the plant shall start from 1 (not from 01). For a typical refinery units see Appendix A.

Steam Tracing Spools

- For steam tracing numbering and material take off, the contractor can use his own system.

	APPENDIX I	
	FLUID ABBREVIATION SYMBOLS	
	a) Air Systems	
	ISA	Instrument Air
	PLA	Plant Air
	b) Blowdown and Pump Out Systems	
	BDN	Blowdown
	CBD	Continuous Blowdown
	IBD	Intermittent Blowdown
	c) Condensate Systems	
	COC	Cold Condensate
	HPC	High Pressure Condensate
	LPC	Low Pressure Condensate
	MPC	Medium Pressure Condensate
	d) Drain (Sewer) Systems	
	CDH	Closed Drain Header
	CSW	Chemical Sewer
	NSW	Non Oily Sewer
	OSW	Oily Sewer
	SSW	Sanitary Sewer
	e) Flare Systems	
	FL	Flare (Normal)
	HFL	High Pressure Flare
	LFL	Low Pressure Flare
	f) Fuels	
	FLG	Fuel Gas
	FLO	Fuel Oil
	NG	Natural Gas
	RFO	Refinery Fuel Oil

APPENDIX I

FLUID ABBREVIATION SYMBOLS

g) Special Gas Systems

ACG	Acid Gas
AIR	Air (Drying Service)
CHL	Chlorine
HEL	Helium
HYD	Hydrogen
NIT	Nitrogen
NOX	Nitrous Oxide
OXY	Oxygen
UTA	Utility Air

h) Special Chemical and Solvent Systems

AMN	Amine
AMO	Ammonia
CAU	Caustic Soda
CHM	Chemicals
DEA	di-Ethanol Amine
DGA	di-Glycole Amine
FS	Flushing Solvent
MEA	mono-Ethanol Amine
MEK	Methyl Ethyl Ketone
TOL	Toluene

APPENDIX I

FLUID ABBREVIATION SYMBOLS

i) Oil Utility Systems

INO	Injection Oil
LBO	Lubricating Oil
SLO	Seal Oil

j) Steam systems

DKS	Decoking Steam
DLS	Dilution Steam
HOR	Hot Oil Return
HOS	Hot Oil Supply
HPS	High Pressure Steam
LLS	Low Low Pressure Steam
LPS	Low Pressure Steam
MPS	Medium Pressure Steam

l) Water Systems

BFW	Boiler Feed Water
CLW	Chlorinated Water
CWR	Cooling Water Return
CWS	Cooling Water Supply
DIW	Distilled Water
HWS	Hot Water Supply
HWR	Hot Water Return
TWR	Tempered Water Return
TWS	Tempered Water Supply
DMW	Demineralized Water
DWA	Drinking Water
FWA	Fire Water
HBW	High Pressure Boiler Feed Water
HCW	Hot and Chilled Water
MBW	Medium Pressure Boiler Feed Water
PHW	Phenol Water
PRW	Process Water
PWA	Plant Water
PTW	Potable Water
QHW	Quench Water
RWA	Raw Water
SWA	Sour Water
TWA	Treated Water
WAT	Water

Appendix I: Process Services

	ACE	Acetylene
	ALC	Alcohol
	ASP	Asphalt
	BZN	Benzene
	BUT	Butane
	CAT	Catalyst
	CRD	Crude
	CRG	Cracked Gas
	ETA	Ethane
	ETN	Ethylene
	FOP	Fuel Oil Product
	GAS	Gas
	GHS	Natural Gas with Hydrogen and Steam
	GSL	Gasoline بنزین
	GSO	Gas oil نفت گاز
	HRG	Hydrogen Rich Gas
	HCB	Hydrocarbon
	HCH	Hydrocarbon with Hydrogen
	HSR	Heavy Straight Run Naphtha
	HNA	Heavy Naphtha
	JP4	Jet Fuel (JP-4)
	JTA	Jet A-1
	KER	Kerosene
	NGH	Natural Gas with Hydrogen

Appendix I: Process Services

LNA	Light Naphtha
LPG	Liquefied Petroleum Gas
MEL	Methanol
MET	Methane
NAP	Naphtha
PNT	Pentane
PRP	Propane
PPN	Propylene
PRA	Process Air
PRO	Process Fluid
RAF	Raffinate
REG	Recycle Gas
RES	Residue
SLG	Sludge لجن غلیظ رسوب مخازن سوخت
SLP	Slop لجن
SUL	Sulfur

APPENDIX L

DEFINITION OF NOMINAL SIZE

- | 1) Definition
- | Nominal size (DN): A numerical designation of size which is common to all components in a piping system other than components designed by outside diameters or by thread size. It is a convenient round number for reference purposes and is only loosely related to manufacturing dimensions.
- | Notes:
 - | 1) It is designated by DN followed by a number.
 - | 2) It should be noted that not all piping components are designated by nominal size, for example steel tubes are designated and ordered by outside diameter and thickness.
 - | 3) The nominal size DN cannot be subject to measurement and shall not be used for purposes of calculation.

TABLE G.1- PIPE COMPONENT-NOMINAL SIZE (METRIC- IMPERIAL)

NOMINAL SIZE		NOMINAL SIZE		NOMINAL SIZE		NOMINAL SIZE	
DN(1)	NPS(2)	DN	NPS	DN	NPS	DN	NPS
6	¼	100	4	600	24	1100	44
15	½	125	5	650	26	1150	46
20	¾	150	6	700	28	1200	48
25	1	200	8	750	30	1300	52
32	1 ^¼	250	10	800	32	1400	56
40	1 ^½	300	12	850	34	1500	60
50	2	350	14	900	36	1800	72
65	2 ^½	400	16	950	38		
80	3	450	18	1000	40		
90	3 ^½	500	20	1050	42		

- 1) Diameter Nominal, mm.
- 2) Nominal pipe Size. Inch.

www.mblastsavior.mihanblog.com

IMPERIAL-METRIC		IMPERIAL	METRIC
PRESSURE CLASSES		PRESSURE CLASSES	PN DESIGNATION
150	20	25	2.5
300	50	125	6
400	68	250	10
600	100	800 ⁽¹⁾	16
900	150	800 ⁽²⁾	25
1500	250		
2500	420		
4500	760		

www.mblastsavior.mihanblog.com

Equivalent pressure ratings designations.

Rating designations which have not exact equivalents

APPENDIX E

PAINTING, INSULATION AND HEAT TRACING DESIGNATION INSULATION OR HEAT

<u>TRACING TYPE</u>	<u>SERVICE</u>
ET	Electrical Traced and Insulated
ETT	Electrical Traced With Heat Transfer Cement and insulated
IS	Insulation for Personnel Protection
SJ	Steam Jacketed and Insulated
ST	Steam Traced and Insulated
STS	Steam Traced With Spacers and Insulated
STT	Steam Traced with Heat Transfer Cement and Insulated
TB	Trace Body and Insulate
PT	Painting
NP	NO Painting, No Insulation
UW	Underground Wrapping

www.mblastavior.mihanblog.com

Numbering for Structure

| Structure and pipe rack shall be numbered in the following manner:

| **Notes:**

| **1) Structure Identification**

| **AT = Antenna Tower**

| **CPS = Concrete Pipe Sleeper**

| **MP = Miscellaneous Platform**

| **PS = Pipe Support**

| **SL = Stiles نردبان**

| **SS = Steel Structure**

| **2) Structure numbering shall be South to North and West to East.**

drawings

Drawing sizes to be used are:

<u>Size Designation</u>	Drawing Dimensions (mm x mm)	Title Block Size (mm x mm)
A4	210 × 297	75 × 120
A3	297 × 420	—
A2	420 × 594	100 × 155
A1	594 × 841	130 × 175
A0	841 × 1189	180 × 190

www.mblastsavior.mihanblog.com

Note:

The final (As Built) isometric drawings shall include the material take off table and should be in **A3** size.

Drawing Scales

- | Drawings scales shall be any of the following:
- | 1 : 10
- | 1 : 20
- | 1 : 25
- | 1 : 33-1/3
- | 1 : 50
- | 1 : 100
- | 1 : 250
- | 1 : 500
- | 1 : 1000
- | 1 : 2500 (Overall Plot Plan Only)

NUMBERING OF PROJECT SPECIFICATIONS AND DATA SHEETS

- I SP
 - I DW
 - I PC
 - I FS
 - I DS
 - I PR
 - I CE
 - I WS
 - I IR
 - I CA
 - I MU
 - I OT
- Specification
 - Drawings
 - Performance Curves
 - Fabrication Schedule
 - Data Sheets
 - Procedures
 - Certificates
 - Welding Specification
 - Inspection Record
 - Calculations
 - Manuals
 - Others

Engineering Disciplines Coding

AC	Heating, Ventilation, Air conditioning & Refrigeration Engineering
CI	Civil Engineering (General) including Architectural
EL	Electrical Engineering
GM	General Machineries
GN	General
HM and/or	Heat and Mass Transfer Engineering (Thermal Equipment Engineering)
IN	Instrumentation Engineering
ME	Fixed Mechanical Equipment Engineering (Non Rotating Equipment Engineering)
PI	Piping Engineering (General Mechanical and Interconnection Engineering)
PR	Process and Chemicals Engineering
PV	Pressure Vessel Engineering (Generally, Vessels Engineering)
RE and/or (PM)	Rotating Equipment and/or (Process Machineries) Engineering
SF	Safety, Fire Fighting & Environmental Control Engineering
ST	Structural Engineering
TC	Telecommunication Engineering
TP	Technical Protection Engineering

Commodity Account No.:

- Civil	01
- Instrumentation	02
- Electrical	03
- Machinery	04
- Heaters	05
- Heat Exchangers (including reboilers, coolers, double pipe heat exchangers, coils, plate heat exchangers, etc.)	06
- Vessels, Towers or Drums	07
- Tanks and Spheres	08
- Package Units	09
- Miscellaneous Mechanical	10
- Piping	11
- Management	12
- Site Construction	13
- Miscellaneous	14

Project Sections Coding

AC	Accounting
CC	Cost Control
CN	Construction
DC	Document Center
FN	Finance
GN	General
PC	Project Coordination
PE	Project Engineering
PN	Planning
PM	Project Management
PQ	Procurement
QA	Quality Assurance
QC	Quality Control

www.mblast Savior.mihanblog.com

Numbering of Drawings

www.mblastsavior.mihanblog.com

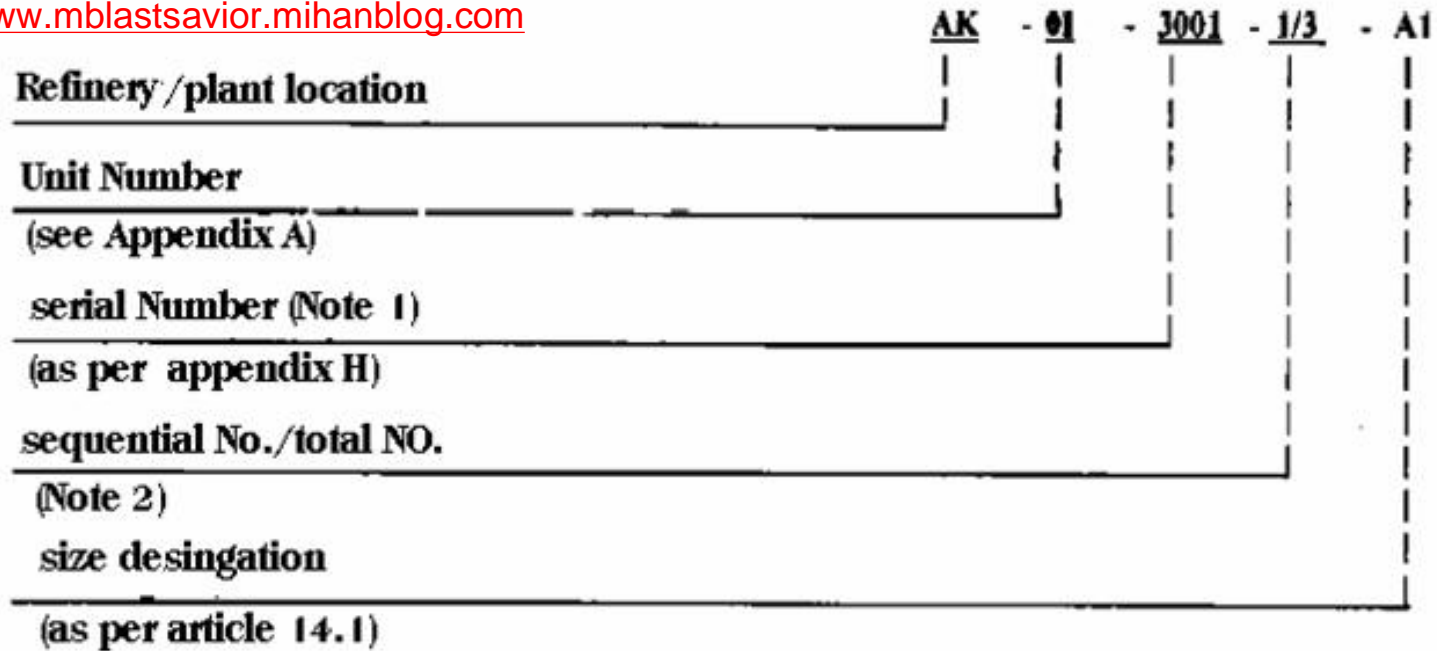

Notes:

- 1) Two drawings may have the same serial number but different unit number.
- 2) When drawings have same title and function, they shall have the same serial number and shall be identified by using Sequential No./Total No.

Numbering of Isometric Drawings

Numbering of Isometric Drawings shall be the same as the piping line number which is shown on the Isometric Drawing.

www.mblastsavior.mihanblog.com

CRD-01-0001A - 1/3

piping line No.

(Refer to article 11.1)

sequential No. /total No.

(for requirements more than one for same line , if needed)

SYMBOLS AND ABBREVIATIONS

<u>SYMBOL/ABBREVIATION</u>	<u>DESCRIPTION</u>
AK	Arak
BD	Building
CRD	Crude
DN	Diameter Nominal, in (mm)
HVAC	Heating Ventilation and Cooling
LG	Level Gage
PDB	Distribution Panel Board
PFD	Process Flow Diagram
P & IDs	Piping and Instrument Diagrams
PO	Purchase Order
PS	Pipe Support
PSV	Pressure Safety Valve
SI	System International
TEL	Tetra Ethyl Lead

www.mblastsavior.mihanblog.com

DRAWING SERIAL NUMBER

<u>TYPE OF DRAWING</u>	<u>SERIAL NUMBER (4 Digits)</u>
- PROCESS FLOW DIAGRAM	0001 - 0099
- MECHANICAL FLOW DIAGRAMS (P & IDs)	0100 - 0199
- UTILITY FLOW DIAGRAM	0200 - 0399
- PLOT PLAN	0500 - 0599
- CONCRETE	1000 - 1999
- STRUCTURAL STEEL	2000 - 2999
- VESSEL	4000 - 4999
- PIPING	5000 - 5999
- ELECTRICAL	6000 - 6999
- INSTRUMENT	7000 - 7999
- INSULATION	8000 - 8999
- MISCELLANEOUS	9000 - 9999

Special Chemical and Solvent Systems

AMN	Amine
AMO	Ammonia
CAU	Caustic Soda
CHM	Chemicals
DEA	di-Ethanol Amine
DGA	di-Glycole Amine
MEA	mono-Ethanol Amine
MEK	Methyl Ethyl Ketone
TOL	Toluene

www.mblastavior.mihanblog.com

FLUID ABBREVIATION SYMBOLS

I a) Air Systems

- I ISA Instrument Air
- I PLA Plant Air

I b) Blowdown and Pump Out Systems

- I BDN Blowdown
- I CBD Continuous Blowdown
- I IBD Intermittent Blowdown

I c) Condensate Systems

- I COC Cold Condensate
- I HPC High Pressure Condensate
- I LPC Low Pressure Condensate
- I MPC Medium Pressure Condensate

I d) Drain (Sewer) Systems

- I CSW Chemical Sewer
- I NSW Non Oily Sewer
- I OSW Oily Sewer
- I SSW Sanitary Sewer

FLUID ABBREVIATION SYMBOLS

I e) Flare Systems

- I FL Flare (Normal)
- I HFL High Pressure Flare
- I LFL Low Pressure Flare

I f) Fuels

- I FLG Fuel Gas
- I FLO Fuel Oil
- I NG Natural Gas
- I RFO Refinery Fuel Oil

I g) Special Gas Systems

- I ACG Acid Gas
- I CHL Chlorine
- I HEL Helium
- I HYD Hydrogen
- I NIT Nitrogen
- I OXY Oxygen
- I UTA Utility Air

FLUID ABBREVIATION SYMBOLS

i) Oil Utility Systems

- | LBO Lubricating Oil
- | SLO Seal Oil
- | FGO Flushing Oil

j) Steam systems

- | DLS Dilution Steam
- | HOR Hot Oil Return
- | HOS Hot Oil Supply
- | HPS High Pressure Steam
- | LLS Low Low Pressure Steam
- | LPS Low Pressure Steam
- | MPS Medium Pressure Steam

FLUID ABBREVIATION SYMBOLS

I) Water Systems

BFW	Boiler Feed Water
CLW	Chlorinated Water
CWR	Cooling Water Return
CWS	Cooling Water Supply
DIW	Distilled Water
HWS	Hot Water Supply
HWR	Hot Water Return
TWR	Tempered Water Return
TWS	Tempered Water Supply
DMW	Demineralized Water
DWA	Drinking Water
FWA	Fire Water
HBW	High Pressure Boiler Feed Water
HCW	Hot and Chilled Water
MBW	Medium Pressure Boiler Feed Water
PRW	Process Water
PWA	Plant Water
RWA	Raw Water
SWA	Sour Water
TWA	Treated Water
WAT	Water

www.mblast Savior.mihanblog.com

FLUID ABBREVIATION SYMBOLS

	k) Process Services	
	ACE	Acetylene
	ALC	Alcohol
	ASP	Asphalt
	BZN	Benzene
	BUT	Butane
	CAT	Catalyst
	ETA	Ethane
	ETN	Ethylene
	FOP	Fuel Oil Product
	GAS	Gas
	GSL	Gasoline
	GSO	Gas oil
	HRG	Hydrogen Rich Gas
	HCB	Hydrocarbon
	HCH	Hydrocarbon with Hydrogen
	JP4	Jet Fuel (JP-4)
	JTA	Jet A-1
	KER	Kerosene
	NGH	Natural Gas with Hydrogen
	RGH	Reformed Gas with Hydrogen

FLUID ABBREVIATION SYMBOLS

LNA	Light Naphtha
LPG	Liquefied Petroleum Gas
MEL	Methanol
MET	Methane
NAP	Naphtha
PNT	Pentane
PRP	Propane
PPN	Propylene
PRA	Process Air
PRO	Process Fluid
RAF	Raffinate
REF	Reformate
REG	Recycle Gas
RES	Residue
SLG	Sludge
SLP	Slop
SUL	Sulfur

ENGINEERING STANDARD FOR LAYOUT AND SPACING

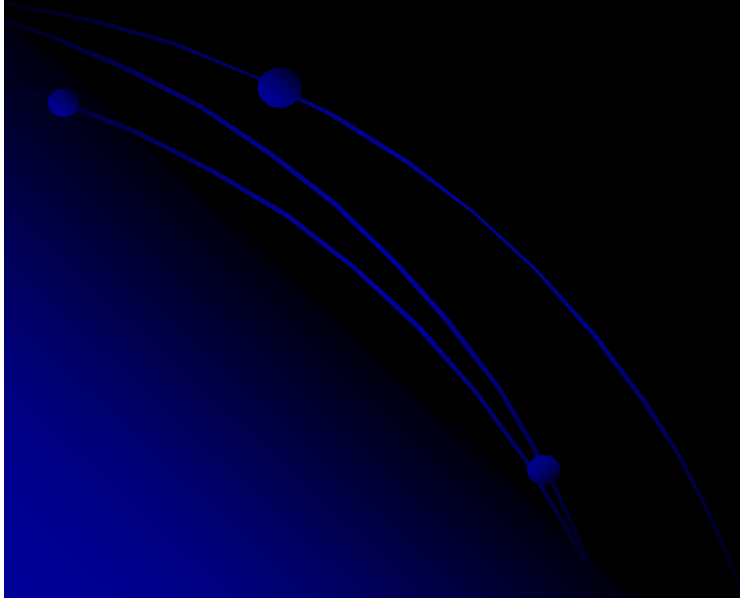

- I This Standard Specification covers the basic requirements of the plant layout and spacing of oil & gas refineries, petrochemical and similar chemical plants to ensure safety and fire prevention together with ease of operation and maintenance.

- | **API (AMERICAN PETROLEUM INSTITUTE)**
- | RP-500 A "Recommended Practice for Classification of Location for Electrical Installation in Petroleum Refineries", Edition Fourth, Jan. 1982
- | API Std. 620 "On Large, Welded, Low Pressure Storage Tanks"
- | API Std. 650 "On Welded Steel Tanks for Oil Storage"
- | **ASME (AMERICAN SOCIETY OF MECHANICAL ENGINEERS)**
- | "Boilers and Pressure Vessel Codes":
- | - Section I, Power Boilers
- | - Section VIII, Pressure Vessels
- | **ASCE (AMERICAN SOCIETY OF CIVIL ENGINEERS)**
- | "Minimum Design Loads for Structures"
- | **IPS (IRANIAN PETROLEUM STANDARDS)**
- | IPS-C-ME-100 "Atmospheric Above Ground Welded Steel Storage Tanks"
- | IPS-E-EL-110 "Electrical Area Classification & Extent"
- | IPS-C-ME-110 "Large Welded Low Pressure Storage Tanks"
- | IPS-C-ME-120 "Aviation Turbine Fuel Storage Tanks"
- | IPS-C-ME-130 "Pressure Storage & Spheres (for LPG)"
- | IPS-E-CE-160 "Geometric Design of Roads"
- | IPS-G-PI-280 "Pipe Supports"
- | IPS-E-PR-360 "Process design of liquid & gas transfer & storage"
- | IPS-E-SF-200 "Fire Fighting Sprinkler Systems"
- | IPS-C-SF-550 "Safety Boundary Limits"
- | IPS-D-PI-102 "Typical Unit Plot Arrangement & Pipeway Layout"
- | IPS-D-PI-103 "Pipeline Spacing"

- | **ANSI (AMERICAN NATIONAL STANDARD INSTITUTE)**
- | ANSI-MSS Standards, "Piping Hanger and Supports", 1969 Edition
- | **NFPA (NATIONAL FIRE PROTECTION ASSOCIATION)**
- | NFPA "Recommendation Codes and Standards" (See Table A-1 in Appendix A)
- | NFPA, 59 "Standard for the Storage and Handling of Liquefied Petroleum Gases", Ed. 1989
- | NFPA, 251 "Standard Methods of Fire Tests of Building, Construction and Materials", Ed. 1985
- | **IRI (INDUSTRIAL RISK INSURANCE)**
- | "Requirement on Spacing of Flare"
- | **TEMA (TUBULAR EXCHANGER MFRS. ASSN. STANDARD)**
- | Uniform Building "From International Conference of Building Office", 1991 Ed.
- | Code, (UBC)

DEFINITIONS AND TERMINOLOGY

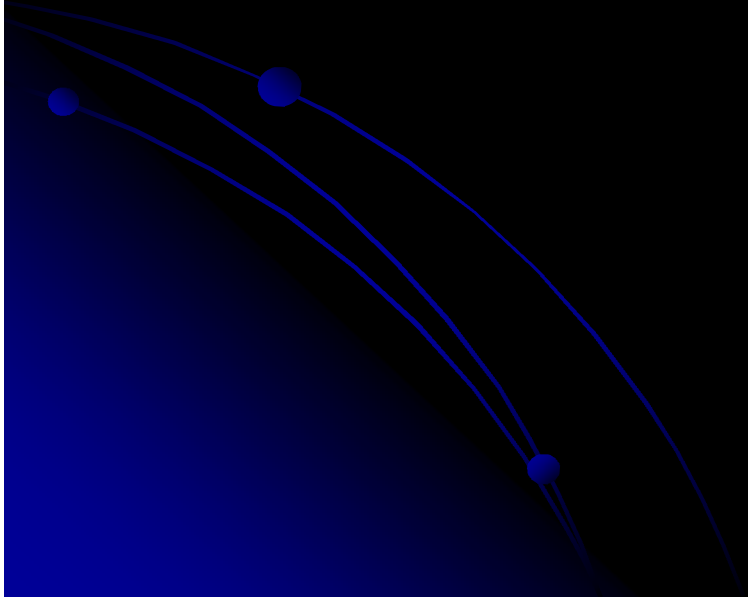

I **Dike بند**

L3

Is an earth or concrete wall providing a specified liquid retention capacity.

I **Diversion Wall**

Is an earth or concrete wall which directs spills to a safe disposal area.

I **Fire Resistive**

Fire resistance rating, as the time in minutes or hours, that materials or assemblies have withstand a fire exposure as established in accordance with the test of **NFPA 251**.

I High Flash Stock

Are those having a closed up flash point of 55°C or over (such as heavy fuel oil, lubricating oils, etc.).

This category does not include any stock that may be stored at temperatures above or within 8°C of its flash point.

I Low-Flash Stocks

Are those having a closed up flash point under 55°C such as gasoline, kerosene, jet fuels, some heating oils, diesel fuels and any other stock that may be stored at temperatures above or within 8°C of its flash point.

I Non-Combustible

Material incapable of igniting or supporting combustion.

I Pipe Rack

The pipe rack is the elevated supporting structure used to convey piping between equipment. This structure is also utilized for **cable trays** associated with electric-power distribution and for **instrument tray**.

I Plot Plan

The plot plan is the **scaled plan** drawing of the processing facility.

I Sleepers

The sleepers comprise the grade-level supporting structure for piping between equipment for facilities, e.g., tank farm or other remote areas.

I Toe Wall

Is a low earth, concrete, or masonry unit curb without capacity requirements for the retention of small leaks or spills.

I Vessel Diameter

Where vessel spacing is expressed in terms of vessel diameter, the diameter of the **largest vessel** is used.

For spheroids, the diameter at the **maximum equator** is used.

I Vessel Spacing

Is the unobstructed distance between vessel shells or between **vessel shells** and nearest edge of **adjacent equipment**, property lines, or buildings.

SYMBOLS AND ABBREVIATIONS

BP	=	Boiling Point
HVAC Conditioning	=	Heating, Ventilation and Air
IC	=	Incombustibles
IRI	=	Industrial Risk Insurance
LPG	=	Liquefied Petroleum Gas
NFPA	=	National Fire Protection Association
OD	=	Outside Diameter
OGP	=	Oil, Gas and Petrochemical
OIA	=	Oil Insurance Association
SIC	=	Sheathed Incombustible
TEMA Association	=	Thermal Exchangers Manufacturers

SOME KEY ISSUES RELATED TO LAYOUT

- | Safety and Environment**
- | Familiarization with pertinent Environmental Regulations, (Local, National and International), and how they might change is essential prior to conclusion of pre-project studies.**
- | Attention shall be given to the pertinent safety regulations, including health and welfare needs. Hazardous and flammable materials require special handling, which can take up layout space.**
- | If the process fluids are especially toxic, layout is affected by the need for close chemical sewers and other protection measures. Security requirements may require special layout design when the plant produces a high-value product.**
- | If a plant site is governed by particular building, piping, plumbing, electrical and other codes, these can affect plant layout. Similar governing standards and regulation**

Throughput

- It is important not only to know the initial capacity but also to have a good feel for how much the plant might be expanded in the future, as well as how likely the process technology is to be modernized. These factors indicate how much space should be left for additional equipment. www.mblastsavior.mihanblog.com
- Multiple processing lines (trains), are often required for the plant. Pairs of trains can either be identical or be mirror images. The former option is less expensive. But the mirror image approach is sometimes preferable for layout reasons. Two such reasons are:
 - a) For operator access via a central aisle.
 - b) The need that the outlet sides of two lines of equipment (pumps, for instance) point toward each other so that they can be readily hooked to one common line.

BASIC CONSIDERATIONS

General

The plant layout shall be arranged for:

- a) maximization of safety;
- b) prevention of the spread of fire and also ease of operation;
- c) maintenance consistent with economical design and future expansion.

Blocking

The plant site shall be blocked in consideration of hazards attendant to plant operation in the area. All blocked areas shall be formed as square as possible by divided access roads and/or boundary lines.

Location and Weather

The plant layout shall be arranged in consideration of geographic location and weather in the region of the site.

Prevailing Wind

Where the prevailing wind is defined, the administration and service facilities and directly fired equipment, etc., shall be located **windward of process Units and storage tanks, etc.**

www.mblastsavior.mihanblog.com

Layout Indication

The basic requirements to be met in the appropriate diagram when making a piping and equipment layout are:

- All **equipment, ladders, structures,** shall be indicated.
- All **instrument** shall be located and indicated.
- All **valving and handwheel orientations** shall be indicated.
- Drip funnel locations for underground drains** shall be indicated.
- All **electrical switch gears, lighting pannels** shall be indicated.
- All **sample systems** shall be indicated

PLANT LAYOUT

I Area Arrangement

- I Classified blocked areas, such as process areas, storage areas, utilities areas, administration and service areas, and other areas shall be arranged as follows:
- I 1) The process area shall be located in the most convenient place for operating the process Unit.
- I 2) The storage area shall be located as far as possible from buildings occupied by personnel at the site, but should be located near the process area for ready operation of the feed stocks and product run-downs.
- I 3) The utilities area shall be located beside the process area for ready supply of utilities.
- I 4) Loading and unloading area shall be located on a corner of the site with capable connection to public road directly, for inland traffics. For marine transportation, the area shall be located on the seaside or riverside in the plant site.
- I 5) The administration and service area shall be located at a safe place on the site in order to protect personnel from hazards. It shall preferably be located near the main gate alongside the main road of the plant.
- I 6) Flare and burn pit shall be located at the end of the site with sufficient distance to prevent personnel hazard.
- I 7) Waste water treating Unit shall be located near at the lowest point of the site so as to collect all of effluent streams from the processing Unit.
- I 8) The process Unit to which the feed stock is charged first, shall be located on the side near the feed stock tanks, to minimize the length of the feed line.
- I 9) The process Unit from which the final product(s) is (are) withdrawn, shall be located on the side near the products tanks to minimize the length of the product run-down line.
- I 10) Process Units in which large quantities of utilities are consumed, should be preferably located on the side near the utility center.

Roadways

- 1) Road and access ways shall offer easy access for mobile equipment during construction and maintenance, fire fighting and emergency escape in a fire situation.
- 2) Unless otherwise specified by the Company, the defined roads shall be made as stated in IPS-E-CE-160, "Geometric Design of Roads".
- 3) Access roads shall be at least 3 m from processing equipment between road edges to prevent vehicle collisions.

Piperacks and Sleepers

- piperack for process Units and pipe sleeps for the off-site facilities shall be considered as the principals support of the pipe way
- Single level pipe racks are preferred, if more than one level is required, the distance between levels oriented in the same direction shall be adequate for maintenance but not less than 1.25 meters

- Maximum piperack widths shall be 10 m. If widths larger than 10 m are required, the piperack shall be designed to be of two stage. Actual widths shall be 110% of the required widths or the required widths plus 1m. In cases where air fin coolers are to be placed on the piperacks, the piperack widths shall be adjusted based on the length of the air coolers.

- Allow ample space for routing instrument lines and electrical conduit. Provide 25% additional space for future instrument lines and electrical
- Provide 20% additional space on the pipe rack for future piping
- Pipe racks outside process areas shall have the following minimum overhead refinery/plant clearances: main roadway -5 meters , access roads -4.5 meters, railroads -6.7 meters above top of rail.

- Typical layout of piperack, for process plants depending on the number of process Units incorporated and the process complexities are given in Figs. 1 through 4 with reference descriptions as follow:
- a) "Single Rack Type" layout, is suitable for small scale process complex consisting of two-three process Units. It is economical without requiring any large area.

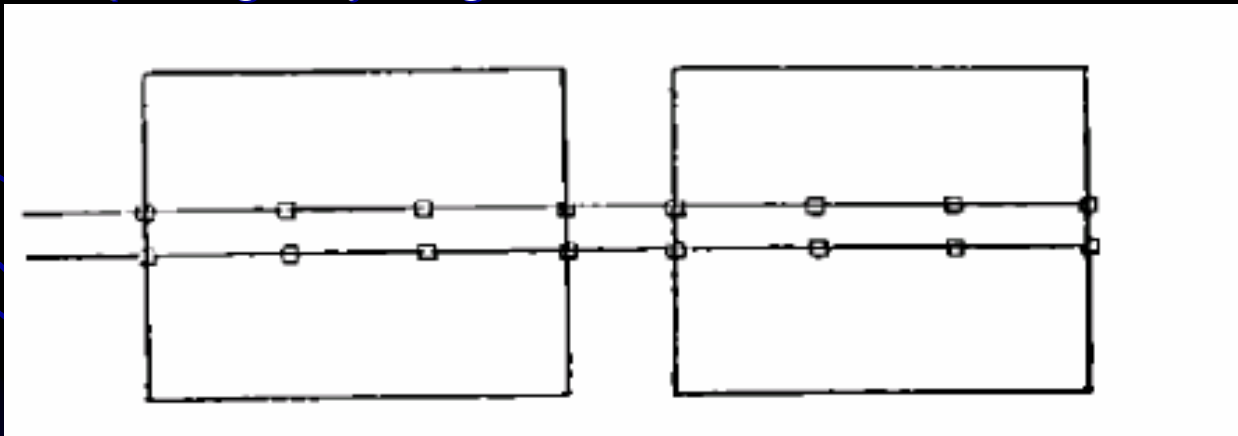

- I "Comb Type" layout shown in Fig. 2, is recommended for use in process, complex consisting of three or more process Units. "Single Rack Type" in this case will not be suitable since separate maintenance and utility administration in normal operation will be difficult because of the utility and flare line which are placed on the common rack.

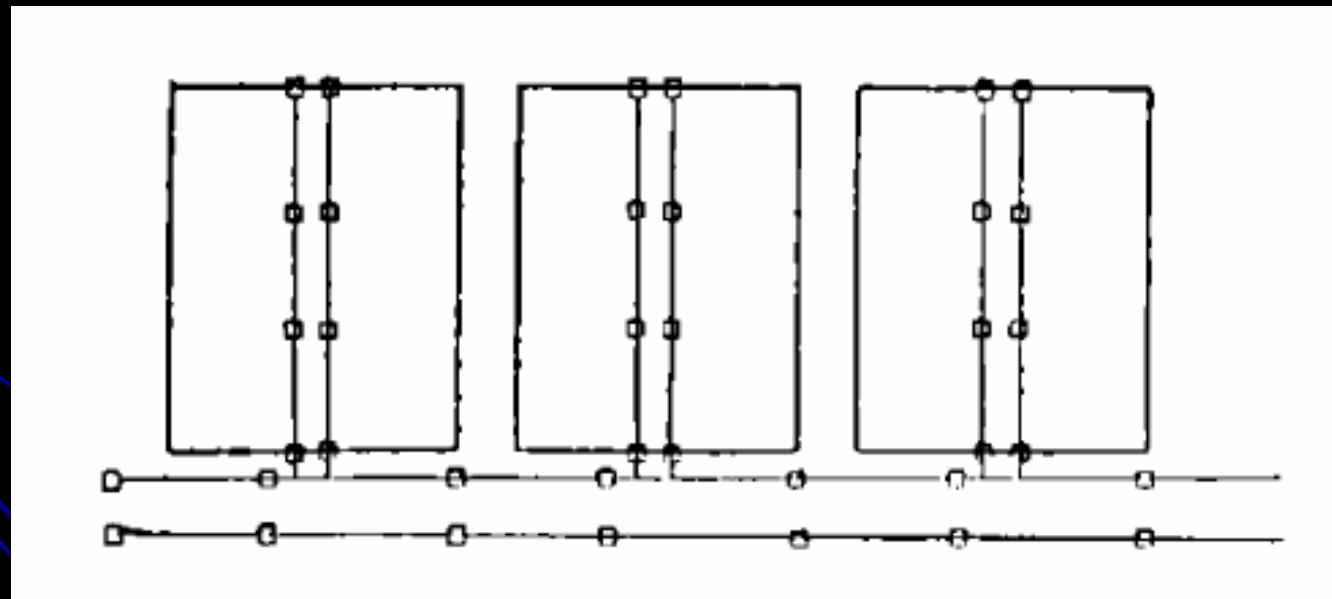

- I "Double Comb Type" layout is an expansion of the "Comb Type" which is recommended for the use in largescale process complexes where five to ten process Units are to be arranged. This layout as shown below in Fig. 3, can be conveniently utilized

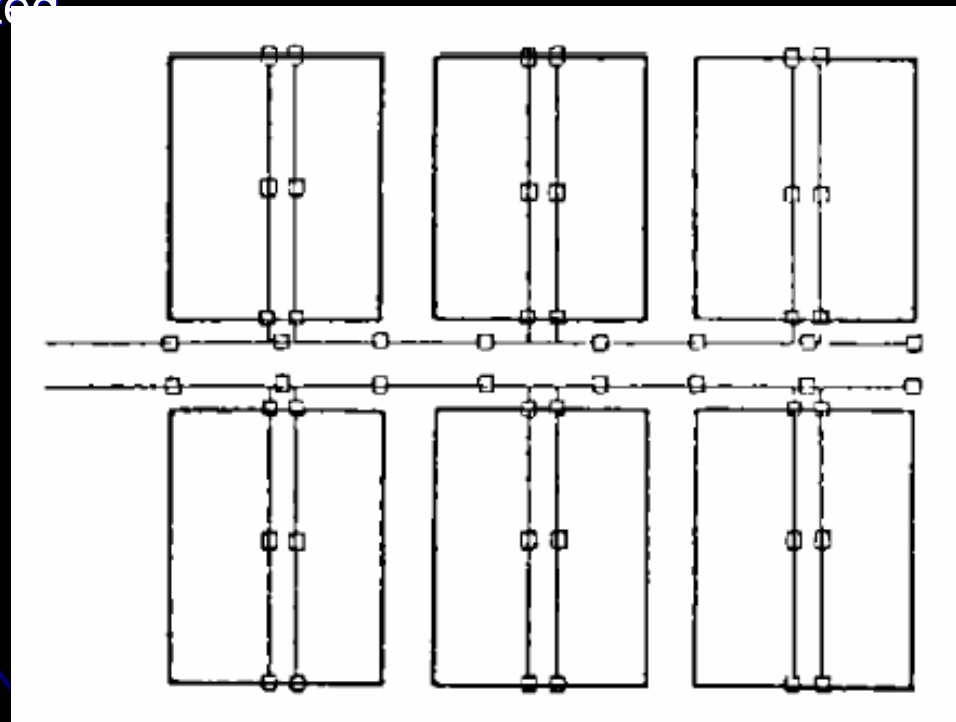

- I "U Type" layout shown in Fig. 4, is recommended to be used in case of process Units whose maintenance cannot be conducted separately, within the complex. This type can be regarded as an expansion of the "Single Rack Type". Even process complexes of this nature, can be regarded as one process Unit in the planning of their layout.

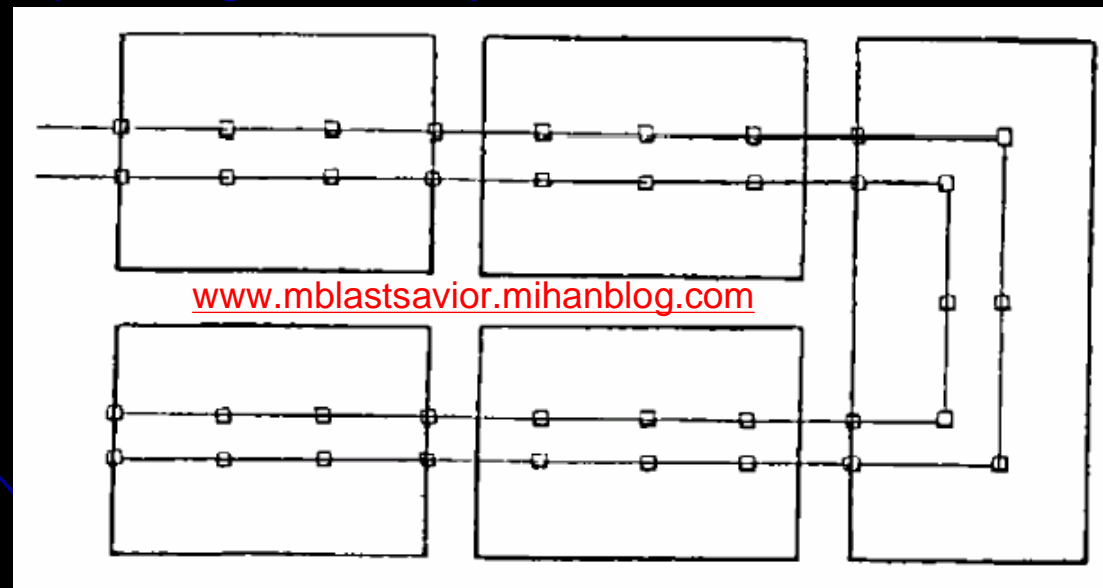

- The control room and substation shall be located from an economical standpoint so as to minimize the length of electrical and instrument cables entering and leaving therefrom
- The control room shall be positioned so that the operator can command a view of the whole system which is under control. Large buildings, or equipment shall not be placed in front of the control room.

APPENDIX A (continue)

TABLE A.7 - PROXIMITY OF REFRIGERATED STORAGE VESSELS TO BOUNDARIES AND OTHER FACILITIES

BOUNDARY LINES OR OTHER FACILITIES	MINIMUM SPACING OF DOME ROOF TANKS	MINIMUM SPACING OF SPHERES OR SPHEROIDS
Property lines adjacent to land which is developed or could be built upon public highways, and main, line railroads	60 m (1)	60 m (1)
Utility plants, buildings of high occupancy (offices, shops, labs, wear-houses etc.)	1½ vessel diameter but not less than 45m not exceed 60 m (1)	60 m (1)
Process equipment (or nearest process unit limits if firm layout not available)	1 vessel diameter, but not less than 45 m need not exceed 60 m (1)	60 m (1)
Non-Refrigerated pressure storage facilities	1 vessel diameter, but not less than 30 m need not exceed 60 m	¾ vessel diameter but not less than 30 m need not exceed 60 m
Atmospheric storage tanks (stock closed cup flash point under 55°C)	1 vessel diameter, but not less than 30 m need not exceed 60 m	1 vessel diameter, but not less than 30 m need not exceed 60 m
Atmospheric storage tanks (stock closed cup flash point 55°C or higher)	½ vessel diameter, but not less than 30 m need not exceed 45 m	½ vessel diameter, but not less than 30 m need not exceed 45 m

Note:

1) Distance from boundary line or facility to centerline of peripheral dike wall surrounding the storage vessel shall not be less than 30 m at any point.



سخن پایانی

به نظر می رسد در عصری که آن را عصر انفجار اطلاعات نامیده اند و من آن را عصر روشن ایران می نامم، بهترین دغدغه برای پیشرفت و ترقی پیدا کردن منابع درست مطالعاتی می باشد. در جزوات اخیر سعی شده است بر اساس تجربه و مطالعه چندین منبع مختلف بهترین سیستم آموزشی برای سریعترین نتیجه گیری ارائه شود. مطمئن باشید که با بخشش علمی به اطرافیان درهای پنهان و ناگشوده علم را بر روی خود گشوده خواهید دید! این درسی است که از طبیعت گرفتم. قدرتمندی و ویران کنندگی یک گردباد به میزان خلا درون آن بستگی دارد. انتقال دانش به دیگران همان منشا خلا علمی شماست.

این جزوه تقدیم می شود به پدر و مادرم که پشتوانه ای بی بدیل برای این حقیر بودند. و با تشکر از تمام کسانی که صمیمانه در این راه یاورم بودند

از منابع دوستان با تشکر فراوان از زحمات این عزیزان در جزوات استفاده شده است:

آموزش Hysys نوشته رضا درستی - غلامرضا باغمیشه

آموزش Aspen Plus نوشته رضا درستی - غلامرضا باغمیشه

آموزش Aspen Plus نوشته محمد پوربافرانی

Rules of thumb for chemical engineers

Carl Branan

Applied process design

ernest ludwig

Chemical process equipment

Stanley walas

به طور قطع این جزوه خالی از اشکال نمی باشد. خواهشمند است در تصحیح و بهتر نمودن آن اینجانب را یاری نمایید.

Email: lastsavior_b@yahoo.com

Weblog: www.mblastsavior.mihanblog.com

www.mblastsavior.blogfa.com